

OPERATOR'S MANUAL

▲ WARNING: This manual contains important safety information. Read manual carefully. Keep manual with trailer at all times.

OPERATOR'S MANUAL FOR VAN AND PLATFORM TRAILERS



Great Dane

DRIVE AWAY WITH MORE



TABLE OF CONTENTS

Operator's Instructions	1	Tire Loads	33
Controlled-Temperature Trailers	2	Spare Tire.....	34
Coupling and Uncoupling	3-7	Rims and Wheels	35-40
Proper Use of Steps and Handholds	8-9	Hubs.....	41
Normal Use	10	Axle Alignment.....	42
Weight Distribution for Van Trailers.....	11-14	Leaf-Spring Suspension	42
Weight Distribution for Platform Trailers.....	15-16	Air-Spring Suspension.....	42
Procedure for Extending and Closing Extendable Trailers	17-18	Exhaust (Dump) Valve Operation	43
Pre-Trip Inspection	19-24	Supports (Landing Gear)	44
Electrical System	25	Parking Brakes.....	45
Wiring Diagram	26	Antilock Brake System	46
Fifth Wheel and Kingpin Engagement	27	Rear, Side and Vent Doors.....	47-48
Suspension Slider	27-30	Warranty.....	49
Qwik Release®.....	29	Reporting Claims and Safety Defects.....	50
Brakes and Air Systems.....	31-32	Service Record.....	51-52
Tires.....	32	Notes.....	53

OPERATOR'S INSTRUCTIONS

This manual has been prepared to assist you in retaining the safety, dependability, and performance that are built into Great Dane trailers. It is essential that this trailer receives periodic inspections, maintenance, and service parts replacement.

This manual includes safety checks that the operator should perform periodically.

You can get help in setting up your trailer preventative maintenance program from the American Trucking Associations in Arlington, VA, by contacting ATA through ATA Customer Service at (866) 821-3468, or at www.atabusinesssolutions.com or www.trucking.org/technology/council.aspx.

IMPORTANT NOTICE

Hazard signal words (such as Warning or Caution) appear in various locations throughout this manual. Additional notes are used to emphasize areas of importance. The following definitions indicate the nature of the consequences of these actions:

 **WARNING:** Indicates hazards of unsafe practices which could result in serious injury or death.

 **CAUTION:** Indicates hazards of unsafe practices which could result in minor/moderate personal injury and/or damage to property.

IMPORTANT

Read this manual carefully. Should you have any questions, contact the Great Dane Customer Service Department immediately for the answers. This manual should be kept with the trailer at all times and should remain with the trailer when it is sold. Replacement manuals Part No. 42101203 can be purchased from Great Dane authorized service parts facilities.

CONTROLLED-TEMPERATURE TRAILERS

It is important that owners and drivers of controlled-temperature trailers be well informed about the trailers limitations and to operate such trailers within their limitations to ensure safety and profitability of the equipment. Following are some year-around guidelines, which are applicable to controlled-temperature trailers:

1. Do not haul frozen foods in trailer designed only to haul chilled products.
2. Do not install a larger capacity mechanical refrigeration unit in a trailer with inadequate insulation and hope to get the job done.
3. Match trailer insulation performance with refrigeration unit output for highest efficiency.
4. Do not expect the trailer to act as a freezer. Products to be hauled should be loaded at a temperature as cold as or colder than the required temperature of the products at the time of delivery.

CAUTION:

Controlled-temperature trailers are designed to transport food and food products. The vehicle must be clean before loading. **DO NOT** transport products or use cleaning agents in these trailers that could cause contamination of any food product.

COUPLING AND UNCOUPLING

Knowing how to couple and uncouple correctly is basic to the safe operation of combination vehicles. General coupling and uncoupling steps are listed below. There are differences between various combinations of tractors and trailers. Learn the specific details of coupling and uncoupling the vehicles you will operate.

⚠ WARNING: Incorrect coupling and uncoupling can result in serious injury or death.

COUPLING Tractor-Semi Trailers

Step 1: Inspect Fifth Wheel

- Check for damaged/missing parts
- Check to see that mounting to tractor is secure, no cracks in frame, etc.
- Be sure that the fifth wheel plate is lubricated as required. Failure to keep the fifth wheel plate lubricated could cause steering problems because of friction between the tractor and the trailer.
- Check if fifth wheel is in proper position for coupling:
 - Wheel tilted down towards rear of tractor.
 - Jaws open.
 - Safety unlocking handle in the automatic lock position.
- If you have a sliding fifth wheel, make sure it is locked in place.
- Make sure the trailer kingpin is not damaged.

Step 2: Inspect Area

- Make sure area around the vehicle is clear.
- Be sure trailer parking brakes are applied.
- Check that cargo is secured against movement caused by the tractor being coupled to the trailer.

Step 3: Position Tractor

- Back the tractor directly in front of the trailer. (Never back under the trailer at an angle, because you might push the trailer sideways and damage the support legs).
- Check position, using outside mirrors, by looking down both sides of the trailer.

Step 4: Back Slowly

- Back until fifth wheel just touches the trailer.
- Do not hit the trailer.

Step 5: Secure Tractor

- Put on the parking brake.
- Put transmission in neutral.

Step 6: Check Trailer Coupler Height

- The trailer should be low enough that it is raised slightly by the tractor when the tractor is backed under it. Raise or lower the trailer as needed. (If trailer is too low or too high, tractor may strike and damage nose of the trailer, **or it may not couple correctly.**)
- Check that the kingpin and fifth wheel are aligned.

Step 7: Connect Air Lines to Trailer

- Check coupler seals and connect tractor supply (emergency) air line to trailer supply (emergency) coupler.
- Check coupler seals and connect tractor control (service) air line to trailer control (service) coupler.
- Make sure air lines are safely supported where they will not be crushed or caught while tractor is backing under the trailer.

Step 8: Supply Air to Trailer

- From cab, push in “Air Supply” knob or move tractor protection control valve from the “Emergency” to the “Normal” position to supply air to the trailer brake system.
- Wait until the air pressure is normal.
- Check brake system for crossed air lines.
 - Shut engine off so you can hear leaks in the brake system.
 - Apply and release trailer brakes. Listen for sound of trailer brakes being applied and released. You should hear the brakes move when applied and air escape when the brakes are released.
 - Check air brake system pressure gauge for signs of major air loss.
- When you are sure trailer brakes are working, start engine.
- Make sure air pressure is up to normal

Step 9: Lock Trailer Brakes

- Pull out the “Air Supply” knob, or move the tractor protection control valve from “Normal” to “Emergency.”

COUPLING *Continued*

Step 10: Back Under Trailer

- Use lowest reverse gear.
- Back tractor slowly under trailer to avoid hitting the kingpin too hard.
- Stop when the kingpin is locked into the fifth wheel.

Step 11: Check Connection for Security

- Raise trailer support legs slightly off ground.
- Pull tractor gently forward while the trailer brakes are still applied.

Step 12: Secure Tractor-Trailer

- Put transmission in neutral.
- Put parking brakes on.
- **Shut off engine and take key with you so someone else will not move the tractor-trailer while you are under it.**

Step 13: Inspect Coupling

- Use a flashlight if necessary.
- Make sure there is **no space between upper coupler and fifth wheel**. If there is space, something is wrong (kingpin may be on top of closed fifth wheel jaws; trailer can come loose very easily).
- Go under trailer and look into the back of the fifth wheel. Make sure the fifth wheel jaws have closed around the shank of the kingpin.

- Check that the locking lever is in the “lock” position.
- Check that the safety catch is in position over locking lever. (On some fifth wheels the catch must be put in place by hand.)
- If the coupling is not right, **do not drive the coupled unit**; get it fixed.

Step 14: Connect the Electrical Cord and Check Air Lines

- Plug the electrical cord into the trailer and fasten the safety catch.
- Check both air lines and electrical line for signs of damage. Repair or replace if necessary.
- Make sure air and electrical lines will not hit any moving parts of vehicle.

Step 15: Raise Trailer Support Legs (Landing Gear)

- With two hands on the crank handle, carefully use low-gear range (if so equipped) to begin raising the support legs. Once free of weight, switch to the high-gear range.
- Raise the support legs all the way up. (Never drive with support legs only part way up as they may catch on railroad tracks or other things.)
- After raising the support legs, properly secure the crank handle.

- With the front of the trailer supported by the tractor,
 - Check for enough clearance between rear of tractor frame and support legs. (When tractor turns sharply it must not hit the support legs or their bracing.)

- Check that there is adequate clearance between the top of the tractor tires and the underside of the trailer.



WARNING: Incorrect coupling and uncoupling can result in serious injury or death.

UNCOUPLING Tractor-Semi Trailers

The following steps will help you to uncouple safely.

Step 1: Position Rig

- Make sure surface of parking area can support weight of trailer.
- Have tractor in a straight line with the trailer. (Pulling out at an angle can damage the support legs and upper coupler.)

Step 2: Ease Pressure on Locking Jaws

- Shut off trailer air supply to lock trailer brakes.
- Ease pressure on fifth wheel locking jaws by backing up gently (this will help you release the fifth wheel locking lever).

- Apply parking brakes while tractor is pushing against the kingpin. This will hold the tractor with pressure off of the locking jaws.

Step 3: Lower the Support Legs

- Use high gear range, hold handle carefully using two hands and lower the support legs until they make firm contact with the ground. Turn crank in low gear a few extra turns. This will lift some weight off the tractor. (Do not lift trailer off the fifth wheel). This will make it easier to unlatch fifth wheel and couple next time.

Step 4: Disconnect Air Lines and Electrical Cable

- Disconnect air lines from trailer. Connect air line couplers to dummy couplers at back of cab.
- Hang electrical cable with plug down to prevent moisture from entering it.
- Make sure lines are supported so they will not be damaged while driving the tractor.

Step 5: Unlock Fifth Wheel

- Raise release handle lock.
- Pull the release handle to “open” position.
- Keep legs and feet clear of the rear tractor wheels to avoid serious injury in case the vehicle moves.

Step 6: Pull Tractor Partially Clear of Trailer

- Pull tractor forward until fifth wheel comes out from under the trailer.
- Stop with tractor frame under trailer (prevents trailer from falling to ground if support legs should collapse or sink).

Step 7: Secure Tractor

- Apply parking brake.
- Place transmission in neutral.

Step 8: Inspect Trailer Support

- Make sure ground is supporting trailer.
- Make sure support legs are not damaged.

Step 9: Pull Tractor Clear of Trailer

- Release parking brakes.
- Check and drive tractor clear.

An informative video, **“Hooking Up Doubles”**, showing the TMC recommended method of safely coupling and uncoupling multiple trailers, is available ATA Customer Service 866-821-3468 or www.atabusinesssolutions.com

PROPER USE OF STEPS AND HANDHOLDS

Use all steps and handholds with extreme caution. Such components are subject to wear, damage and environmental conditions. Make sure these components are firmly attached and properly maintained. If you suspect that they are not, **do not use them**. If steps are wet, iced or for some reason seem to be slippery, **they must not be used**.

Steps and handholds are provided on the front wall corners as part of optional vent door packages. They should only be used for access to the vent door. **They must not be used** to start, inspect or maintain any heating or cooling unit installed on the front wall of the vehicle.

On all models, no attempt should be made to secure a vent in an open position unless the vent holdback is securely installed and functioning.

CLIMBING PRACTICES

1. Store clipboards, phones and all other objects prior to climbing. Hands must be free.
2. Face inward (toward the trailer) at all times while ascending and descending.
3. Maintain a three-point contact at all times.
4. Wear slip-resistant footwear.

ACCESS FROM THE GROUND

Use the front wall steps only when the trailer is properly supported by extended support legs. You must use a step ladder, or other structure specifically designed for the purpose of ascent and descent, of an adequate height to safely reach the bottommost step.

ACCESS FROM THE TRACTOR

If the tractor is not equipped with adequate steps, handholds and slip-resistant deck plate to the rear of the cab, **Do Not Attempt Access To The Trailer Steps From The Tractor**. Use “Access From The Ground” method. If the tractor is properly equipped with steps, handholds and a deck plate and the tractor is coupled and locked to the trailer, it is most important that the tractor be in a partial “jackknife” orientation. The tractor must be positioned such that the deck plate is directly beneath the lowest step.

WARNING:

1. **DO NOT** climb on steps not firmly attached and properly maintained.
2. **DO NOT** climb on steps with any item in your hands.
3. **DO NOT** use a tractor not equipped with a safe, adequate climbing system to access the trailer’s front wall steps.
4. **DO NOT** step on tires, fenders, tractor frames, or mudflap supports.
5. **DO NOT** step over air and electrical lines between the tractor and the trailer. Disconnect and properly store if necessary.
6. **DO NOT** use any portion of the tractor in conjunction with any portion of the trailer simultaneously in a “spread-eagle” hold or stance for support.
7. **DO NOT** use an access system if wet, iced, or for any reason seems to be slippery.
8. **DO NOT** use a trailer’s front wall access system to start, inspect, or maintain any heating or cooling unit.
9. **DO NOT** climb higher than necessary to open, secure or close the vent door.
10. **DO NOT** remain on a trailer’s access system while the trailer is being coupled to or uncoupled from a tractor.
11. **DO NOT** jump from the trailer to the ground.

NORMAL USE

This Great Dane trailer was designed for operation within legal highway speed limits on reasonable road surfaces in accordance with the following:

1. This trailer was built to carry cargo within the limitations of weight ratings shown on the certification label. These ratings, GAWR and GVWR are:
 - a. **The GAWR** (gross axle weight rating) is the structural capability of the lowest rated member of the running gear components: suspension system, hubs, wheels, drums, rims, bearings, brakes, axles, or tires.
 - b. **The GVWR** (gross vehicle weight rating) is the structural capability of the trailer when supported by the upper coupler and axles with the load uniformly distributed throughout the cargo space. **CAUTION!** The maximum load indicated on the certification label may or may not be a legal load on the highway you plan to use.
2. This trailer will carry a total payload equal to the Gross Vehicle Weight Rating (GVWR) less the weight of the trailer. The load must be uniformly distributed, or it must be uniformly distributed except for up to 25,000 pounds that must be evenly distributed in any 10 linear feet of trailer length. Recommended payload distributions are shown in Figures 1, 2, and 3.
3. **NOTE:** Exceptions to the above are meat rail trailers. For the maximum allowable suspended load, see the vehicle certification label.
4. The cargo should be properly loaded, blocked, and braced to prevent load shifts and to comply with the following sections of the Department of Transportation Federal Motor Carriers Safety Regulation, Subpart 1 – Protection Against Shifting or Falling Cargo: **Section 393.100 -393.114** – General Rules for protection against shifting or falling cargo – including front end structure. **Section 393.116 -393.136** – Rules for specific types of cargo or loads.

 **WARNING:** Walk carefully in the trailer. The floor may be slippery. Enter and leave only from a dock as high as the floor or by means of a substantial ladder. Advise others of these precautions.

 **CAUTION:** Operation of the trailer outside the limitations of this manual is against federal law and Great Dane design criteria. Any operation exceeding the limitations stated will void any responsibility of Great Dane for the results.

WEIGHT DISTRIBUTION FOR VAN TRAILERS

FIGURE 1.

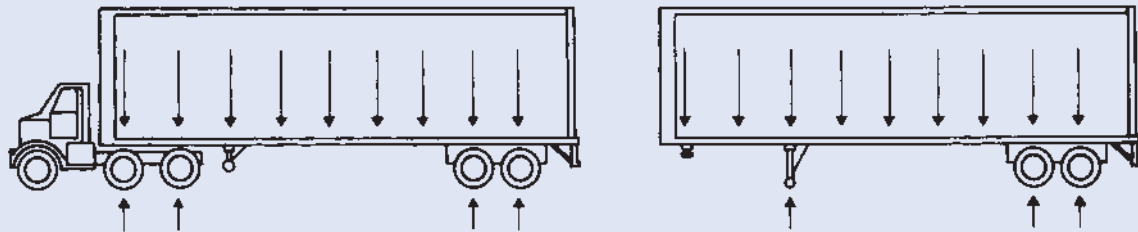

Trailers are designed for uniform load distribution as shown. The load should be distributed uniformly from front to rear.

FIGURE 2.

WRONG

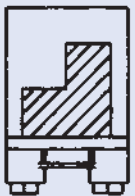

Secure against lateral load movement.

RIGHT

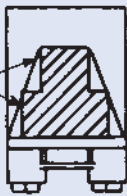

Crosswise weights should be equally distributed. A heavy load should not be loaded on one side because this will overload springs and tires on that side. Place load so that weight will be equal on rear tires, eliminating possible twisting of the frame and overloading of axles and wheel bearings.

Continued



WARNING:

PREVENT TRAILER ROLLOVER

THESE INSTRUCTIONS MUST BE FOLLOWED TO MAXIMIZE TRAILER STABILITY AND MINIMIZE ROLLOVER HAZARD WITH SUSPENDED MEAT CARGO. ANY CARGO MOVEMENT UNDER ADVERSE HANDLING CONDITIONS, SUCH AS AN ACCIDENT AVOIDANCE MANEUVER, MAY CAUSE VEHICLE INSTABILITY AND RESULT IN ROLLOVER

LOADING

1. LOAD HINDQUARTERS AND FOREQUARTERS IN SEPARATE GROUPS.
2. PACK SUSPENDED MEAT CUTS TIGHTLY TOGETHER AND TIGHTLY AGAINST WALLS TO MINIMIZE CARGO MOVEMENT.
3. USE LONG MEAT HOOKS AND DOUBLE HOOKING WHERE POSSIBLE TO LOWER LOAD CENTER OF GRAVITY. KEEP VERTICAL SPACE BETWEEN TRAILER FLOOR AND BOTTOM OF MEAT CUTS TO A MINIMUM.
4. BALANCE WEIGHT OF SUSPENDED MEAT CUTS EVENLY FROM SIDE TO SIDE TO KEEP LOAD CENTER OF GRAVITY OVER CENTER OF TRAILER.
5. DO NOT OVERLOAD TRAILER. SEE CERTIFICATION PLATE FOR GROSS VEHICLE WEIGHT RATING (GVWR) AND GROSS AXLE WEIGHT RATING (GAWR).
6. MAXIMUM ALLOWABLE SUSPENDED LOAD, INCLUDING HOOKS, IS 40,000 LBS (18,144 KG) UNIFORMLY DISTRIBUTED, NOT TO EXCEED 833 LBS (378 KG) FOR EACH FOOT OF TRAILER LENGTH.

WEIGHT DISTRIBUTION FOR VAN TRAILERS *Continued*

Loading heavy concentrated loads not occupying full trailer floor area

FIGURE 3.

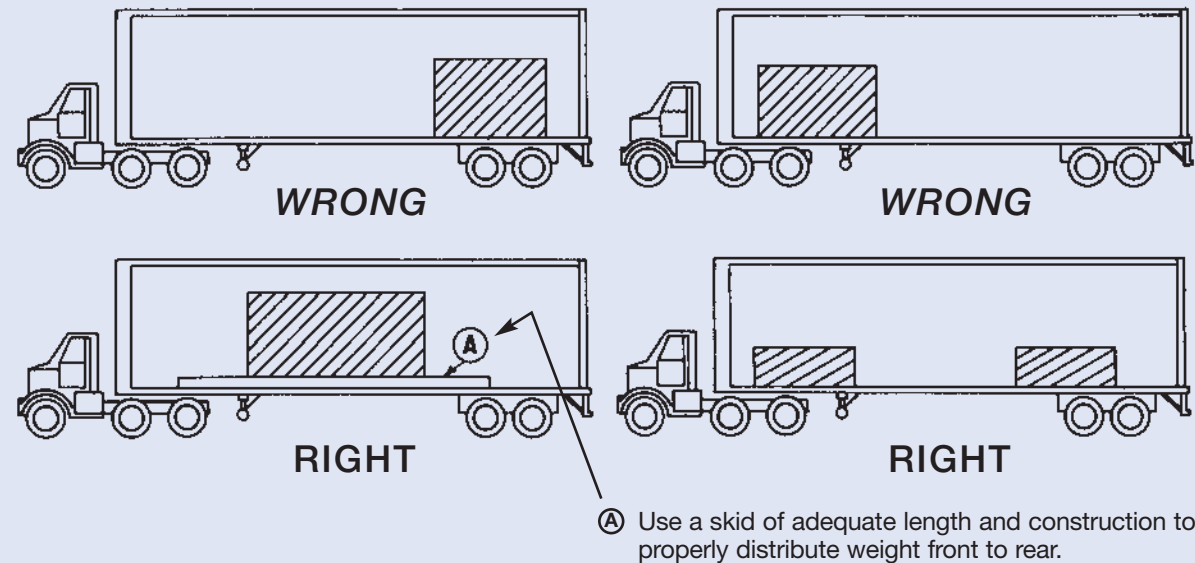

[This page intentionally left blank]

WEIGHT DISTRIBUTION FOR PLATFORM TRAILERS

FIGURE 1.

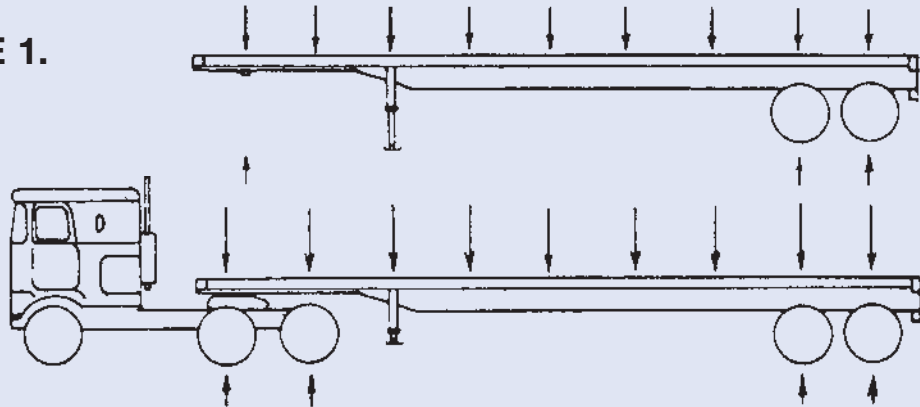

Trailers are designed for uniform load distribution as shown. The load should be distributed uniformly from front to rear.

FIGURE 2.

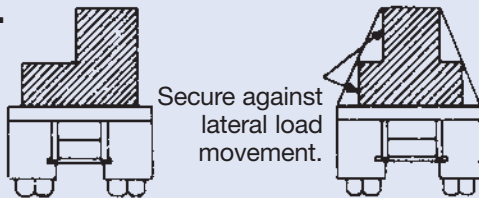

Crosswise weights should be equally distributed. A heavy load should not be loaded on one side because this will overload springs and tires on that side. Place load so that weight will be equal on rear tires, eliminating possible twisting of the frame and overloading of axles and wheel bearings.

Loading heavy concentrated loads not occupying full trailer floor area

FIGURE 3.

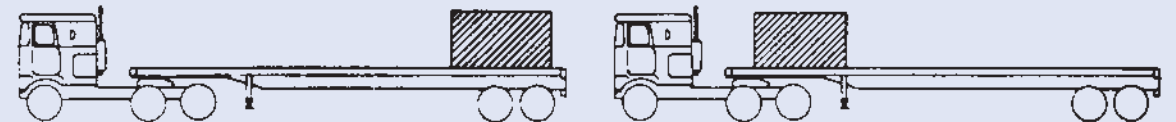

WRONG

WRONG

Use a skid of adequate length and construction to properly distribute weight front to rear.

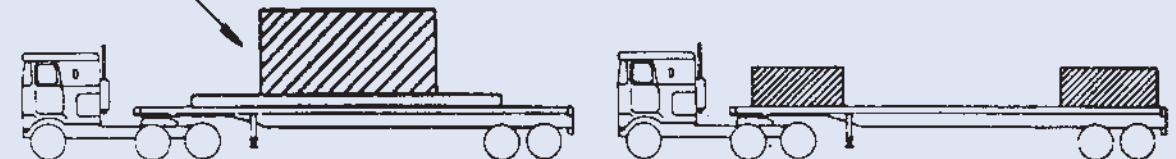

RIGHT

RIGHT

EXTENDING AND CLOSING EXTENDABLE TRAILERS

To Extend the Trailer:

1. Charge the brake system
2. Apply the trailer brakes.
3. Operate the handle on the locking pin actuator to retract the locking pins or apply air to third gladhand, depending on age of trailer.
4. Pull the tractor ahead until the locking pins are just short of the desired locking hole.
5. Operate the handle on the locking pin actuator to move the pins into the locking position. On newer trailers, pins are moved into locking position by returning the gladhand to the normal position, reversing what was done in step 3.
6. Pull the tractor forward until the pins engage the locking holes. Make visual check and gently rock the trailer forward and backward to be sure both pins are clearly through the inner beams.

To Close the Trailer:

1. Charge the brake system
2. Apply the trailer brakes.
3. Operate the handle on the locking pin actuator to retract the locking pins or apply air to third gladhand, depending on age of trailer.

4. Back the tractor until the locking pins are just short of the desired locking hole.
5. Operate the handle on the locking pin actuator to move the pins into the locking position. On newer trailers, pins are moved into locking position by returning the gladhand to the normal position, reversing what was done in step 3.
6. Back the tractor until the pins engage the locking holes. Make visual check to be sure both pins are clearly through the inner beams.

LOAD RATINGS: Rigid, self-supporting loads: 60,000 lbs. Flexible, non-self-supporting loads (lbs.):

OVERALL LENGTH	40-65	45-75	48-80	53-90
45'	50,000	—	—	—
50'	40,000	45,000	—	—
53'	—	—	44,000	—
55'	32,000	35,000	—	—
58'	—	—	34,000	43,000
60'	28,000	28,000	—	—
63'	—	—	28,000	35,000
65'	25,000	25,000	—	—
68'	—	—	23,000	30,000
70'	—	21,000	—	—
73'	—	—	21,000	26,000
75'	—	18,000	—	—
78'	—	—	19,000	22,000
80'	—	—	18,000	—
83'	—	—	—	19,000
88'	—	—	—	18,000
90'	—	—	—	15,000

⚠ WARNING: Stay clear of open area while extending and closing.

NOTES:

1. Bolsters must be used for blocking to avoid damage to inner sections of beams.
2. Position bolsters as far away from open section as possible to avoid breaking of neck and front of rear section.
3. If sliding tandem is used, move slide forward for best loading.
4. Chain tie downs must be of sufficient capacity and must be tightly secured.

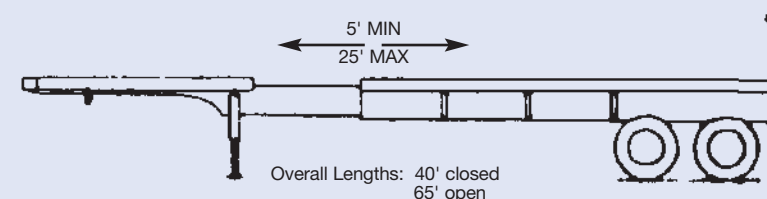

Rigid, Self supporting load

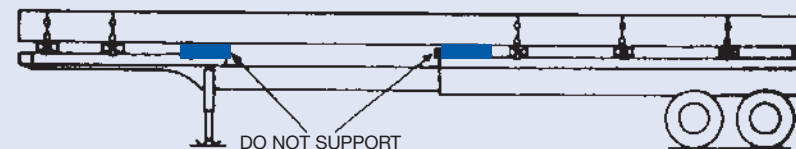

flexible load

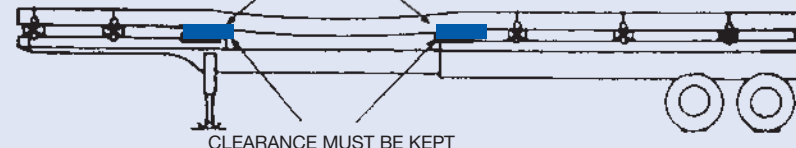

PRE-TRIP INSPECTION

Inspection procedure before each trip

Even though the responsibility for checks and adjustments of a vehicle may belong to the shop or mechanical department, an operator should never take the condition of a tractor or trailer for granted. For the operator's own best interest, and because it is a Federal Motor Carrier Safety requirement, it is important to make thorough pre-trip inspections, on-the-road observations, and written reports on the equipment on a regular basis.

Approaching vehicle

Look for oil, water, or fuel leaks.

Inside cab



1. Apply parking brake, start engine.



2. Check oil pressure, warning lights, air pressure. Deplete pressure until warning buzzer sounds



3. Sound the horn, test for excess amount of wheel play.



4. Test washer-wiper and examine windshield for cracks.



5. See if mirrors on both sides of the cab are clean and aligned.



6. Test heater-defroster blower.



7. Check for charged fire extinguisher and emergency equipment.



8. Turn on all lights (low beam headlamps), emergency flasher and apply trailer parking brakes.

⚠ WARNING:

When you make inspections, hookups, or repairs, be careful how you position your body, because the trailer or tractor might move unexpectedly and cause injury.

Leave cab (engine running) & walk toward rear



1. Make sure the fuel tank cap is tightly secured, no leaks.



2. Examine rear tractor wheels, wheel nuts and tires. Check tires for proper inflation and abnormal wear.



3. Make sure fifth wheel is locked.



4. See if electrical connector is firmly seated and that cord is free from chafing.



5. Inspect air hoses for chafing, air leaks, and proper support.



6. Make sure the landing gear is raised and the handle is securely stowed in the crank handle holder.



7. Where applicable, check for proper placard and shipping papers.



9. Where applicable, inspect sliding tandem lock.
10. Inspect trailer wheels and tires. Listen for air system leaks.



8. Inspect and clean sidemarker lights and reflective material.



11. Inspect and clean conspicuity tape.

Rear of trailer

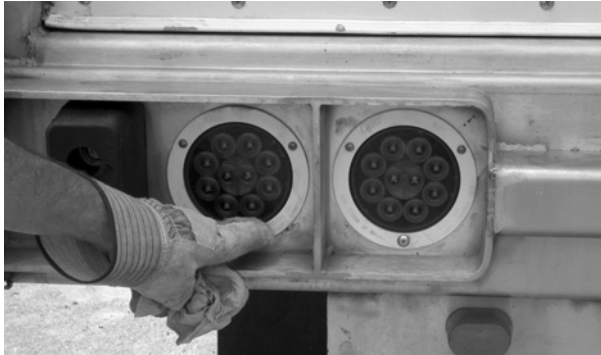

1. See if all lights are working properly, and clean as required.



2. Make sure all doors are secured.

Right side of vehicle

Inspect lights, conspicuity tape, reflectors, tires, and wheels as was done for the left side.

Front of tractor



1. Inspect front tires, wheels and wheel nuts.



2. Inspect headlamps, clearance lights, identification lights, flashers, and turn signals.

Back in cab

1. Depress dimmer switch, observe high-beam light.
2. With trailer brakes still on, release tractor brakes and (in first gear) gently engage clutch to test tractor-trailer coupling.
3. Apply foot brake for one minute. Air loss should not exceed 4 psi per minute for combination rig.

WARNING:

Most pre-trip inspections are visual. Check electrical wiring, brake hoses and other brake components, distorted or broken structural components and welds. Report all defects to the proper persons before deciding to start your trip.

ELECTRICAL SYSTEM

CAUTION: See Connector Wiring Change caution inside front cover.

The electrical system on every Great Dane trailer meets or exceeds all federal and state requirements in effect at the time of manufacture. Wherever required by law, lamps and reflective materials are marked by the manufacturer to indicate the appropriate specification with which each complies.

For optimum performance and long life from the trailer's lamps and wiring, follow this inspection procedure.

Clean reflective materials and lamps. See that all lamps burn properly. Replace all burned out lamps and damaged reflective material. Factory approved replacement parts should be used, and replacement bulbs of equal candlepower should be used for safety.

WARNING:

Do not exceed 21 candlepower for incandescent dome lamps. Stronger bulbs may generate excessive heat and start a cargo fire. Cargo must be kept away from dome lamps. Dome lamps must be turned off for over-the-road operation.

Use only a 12-volt DC battery for checking lamps or antilock brake systems. Never use battery chargers or transformers.

Inspect all wiring to see that it is not frayed, and that it is properly supported and protected, with all connections tight. See that the electrical cable is clean and long enough to permit "jackknife" maneuvers. Be certain that the cable is supported so that it cannot be pinched or entangled by the lower and upper couplers. Keep the plug on the electrical cable and the receptacle on the trailer free of corrosion.

WARNING:

TRAILER IS EQUIPPED WITH ANTILOCK BRAKE SYSTEM (ABS). NO. 7 (BLUE) CIRCUIT IS RESERVED FOR CONTINUOUS POWER SUPPLY TO ABS FOR MOST EFFECTIVE ABS OPERATION, TOWING VEHICLE MUST SUPPLY MINIMUM OF 10 AMPS AT 12.5 VOLTS ON NO. 4 (RED) & NO. 7 (BLUE) CIRCUITS.

PIN	COLOR	CIRCUIT
1	WHITE	GROUND RETURN TO TOWING VEHICLE
2	BLACK	CLEARANCE, SIDE MARKER & ID LAMPS
3	YELLOW	LEFT TURN SIGNAL & HAZARD LAMPS
4	RED	STOP LAMPS & ABS POWER
5	GREEN	RIGHT TURN SIGNAL & HAZARD LAMPS
6	BROWN	TAIL, LICENSE, CLEARANCE & SIDE MARKER LAMPS
7	BLUE	ABS CONTINUOUS SHARED POWER

FAILURE TO HEED THIS WARNING CAN RESULT IN PROPERTY DAMAGE, SERIOUS INJURY OR DEATH.

WIRING DIAGRAM

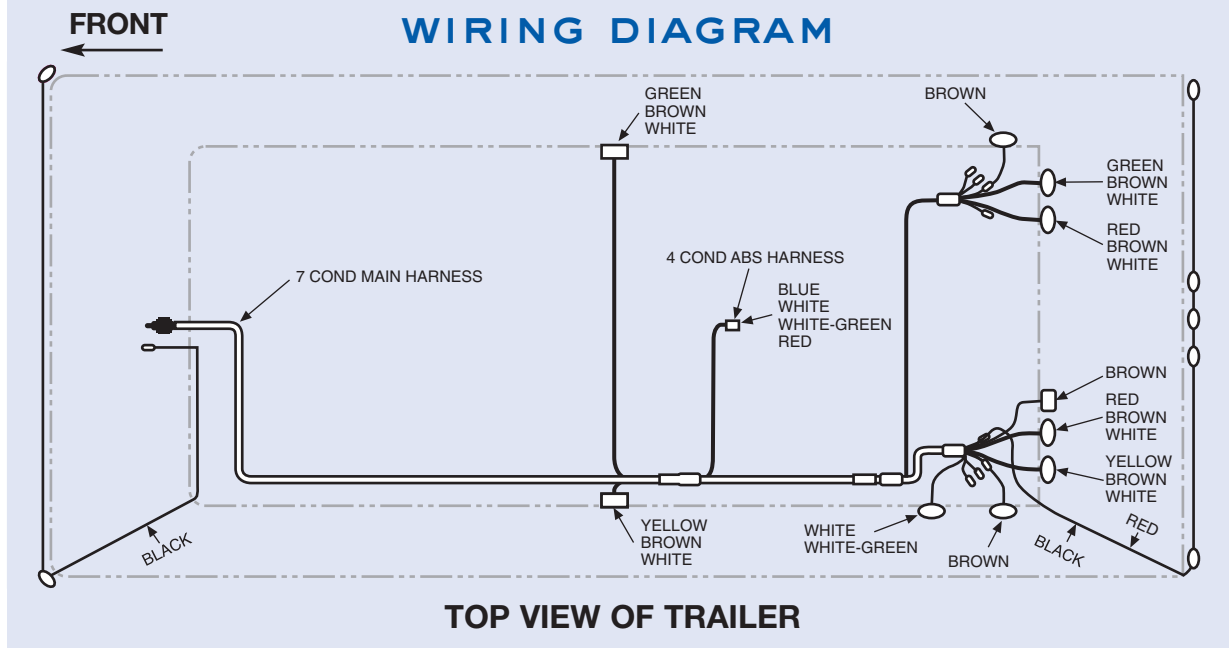

Never replace fuses or breakers with metal foil or other devices.

A decal, similar to the one shown here, is located on the front of each trailer. You may trace individual electrical circuits by the wire colors indicated.

Refer to the schematic drawing and the decal for conductor numbers and wire colors.

FIFTH WHEEL AND KINGPIN ENGAGEMENT

Inspect the kingpin and the upper coupler on the trailer at regular intervals to be sure that they have not suffered damage or undue wear. Although the kingpin is made of hardened forged steel, it is still subject to wear and can be chipped or broken with abuse. Always check the bottom locking flange of the kingpin to determine its condition. The upper coupler fasteners should be inspected to see that they are in place and properly tightened.

Before coupling the trailer to its tractor be certain that the tractor fifth wheel is properly lubricated and the fifth wheel jaws are open to receive the kingpin.

SLIDER FOR VAN TRAILERS

1. If your trailer has a sliding undercarriage, visually inspect to see that all locking pins have fully penetrated the upper slide rails and locked before moving the trailer.
2. The slider may be equipped with a manual stop bar that should be in good working order. If so, this bar should always be locked in place immediately behind the slider unit when the trailer is being operated unless slider is in rearmost position, then place manual stop bar just in front of slider.
3. Be certain that the slider hold-downs are fastened in place and properly situated to prevent separation of the lower slide unit

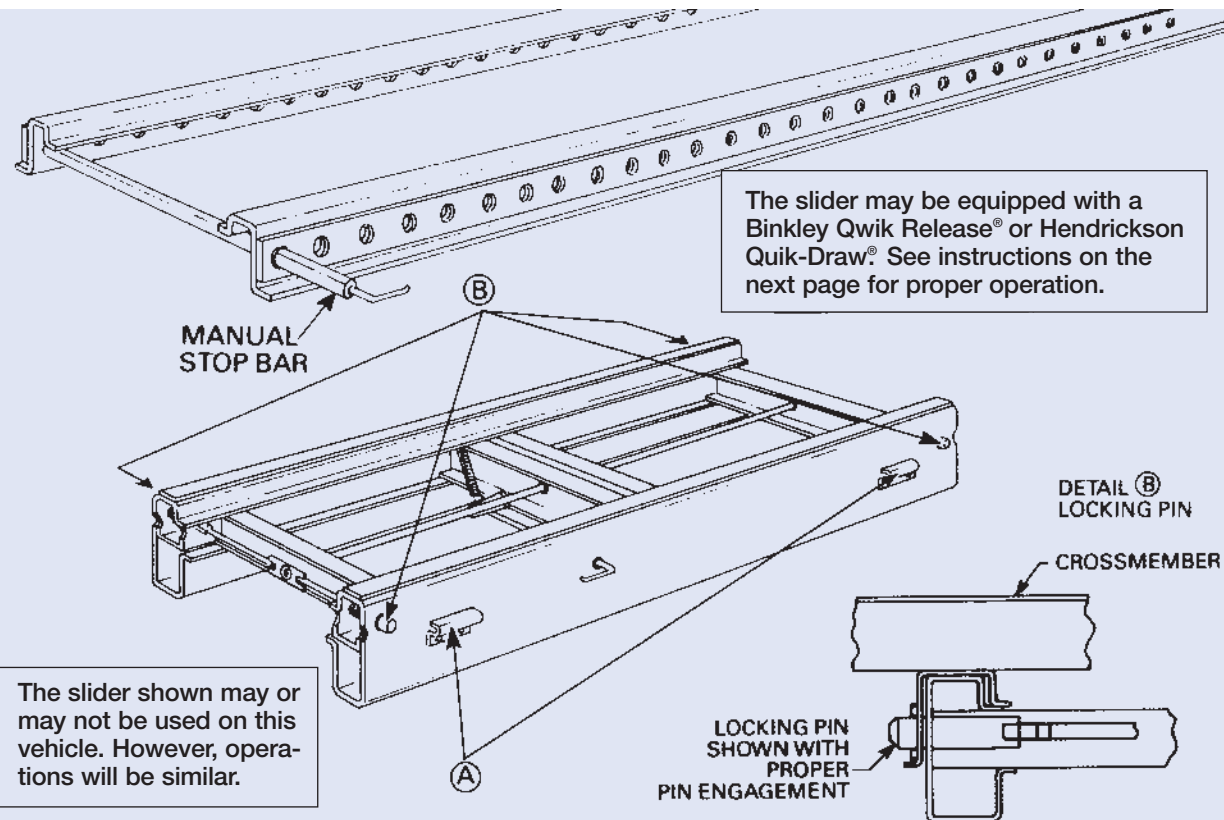
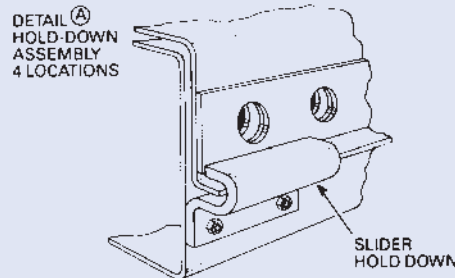

Qwik Release®

Many sliding running gear assemblies are equipped with Spring-loaded Qwik Release device to retract the pins locking the slider frame to the upper rails.

To Position Slider:

1. Remove stop bar and move to desired location.
2. Lift pull arm and pull until locked in the “out” position. If lock pins do not retract after pull arm is lowered in the “out” position, gently rock trailer with brakes applied and pins will automatically retract.
3. Apply trailer brakes and carefully move trailer until contacting stop bar.
4. Release pull arm to the “in” position and visually check all lock pins for proper engagement.
5. Locate manual stop bar immediately behind slider.

Quik-Draw®

Many sliding running gear assemblies are equipped with air-assisted Quik-Draw pin pull mechanisms to retract the pins locking the slider frame to the upper rails.

To Position Slider:

1. Remove manual stop bar and move to desired location.
2. Apply trailer parking brakes.
3. Pull the Quik-Draw control valve knob (located on a control panel at the forward driver’s side of the slider assembly) out to its fully extended position. This pneumatically retracts the slider pins.
4. Inspect each slider pin. Ensure that each pin is fully retracted. If necessary, the trailer can be gently rocked forward and then rearward to fully retract the pins.
5. While keeping the trailer brakes applied, reposition the slider by slowly moving the trailer forward or rearward to the desired position – contacting the stop bar.
6. Push the Quik-Draw control valve knob all the way in. This deflates the actuators, causing the slider pin springs to force the slider pins outward into the slide box and running gear rail holes.
7. Inspect each slider pin. Ensure that each pin has fully extended. If necessary, the trailer can be gently rocked forward and then rearward to completely engage misaligned slider pins.
8. Locate manual stop bar immediately behind slider.

SLIDER FOR PLATFORM TRAILERS

1. If your trailer has a sliding under-carriage, visually inspect to see that all four locking pins have fully penetrated the web of the main beam and locked before moving the trailer. Anytime the body of a locking pin does not protrude past the outside surface of its mating hole, retract and release the pins until they do. Sometimes rocking the trailer back and forth will free a binding condition between the slider and the trailer, allowing the pins to work freely.
2. Always check the condition of the holes in the main beam. Holes that are badly worn or elongated will result in undue slack in the slider unit, causing excessive wear and suspension misalignment.
3. Always check to see that the hold-down brackets are in good repair and have not been damaged. Trailers should not be operated if any of these brackets are not in proper position.
4. Check the pin cage assembly bolts for tightness after each year of service. Re-torque to 380 lb-ft.

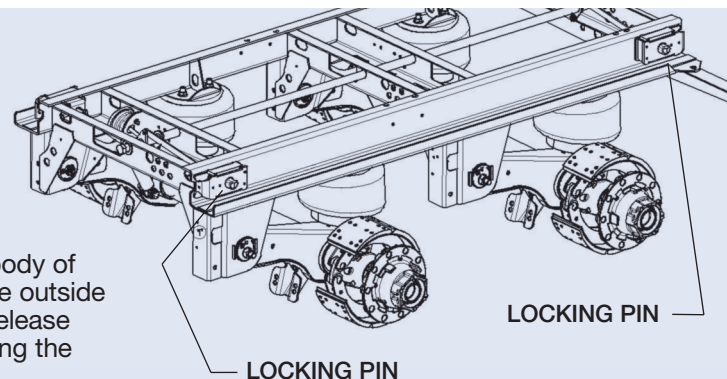

Detail (A)

LOCKING PIN AND HOLD-DOWN ASSEMBLY

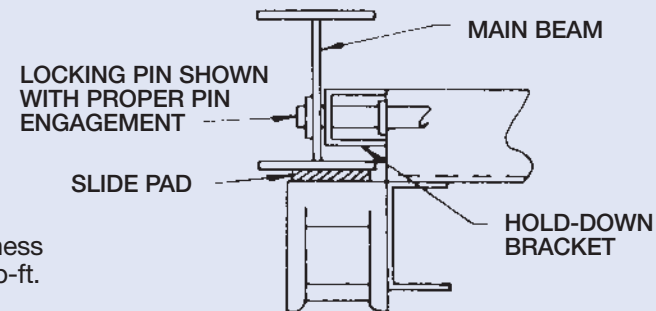

Care and Adjustment of Brakes

The trailer brake systems will perform safely and efficiently only as long as you maintain them properly and do not abuse them. Trailer brakes should be inspected and adjusted frequently in connection

with a Trailer Preventive Maintenance Program. Out-of-adjustment brakes can cause increased stopping distance, shorter brake component life, and a greater tendency for the trailer to jackknife.

AIR SYSTEM AND BRAKE OPERATION

Proper operation of the brake systems requires a firm seal between the air brake couplers. Inspect the couplers for seal damage and cracked housings. Inspect the air hoses for cracking and for frayed connections. Replace or repair damaged components.

Keep the air system clean. Air tanks should be drained daily to remove moisture and other contaminants, especially during cold weather operations.

Use of additives as antifreeze in the air brake system is not recommended. They may result in deterioration of valve seals and performance of the brake system.

Keep the air system tight. The air system cannot be charged properly if there are leaks in reservoirs, lines, hoses, or valves. Always check the tractor pressure gauge for unusual drops or extended buildup times.

If you use Teflon tape or other thread sealers to seal threaded connections in your air lines, be careful not to allow pieces of the sealer to enter the air system.

They can clog passages into the valves.

Run the tractor engine until the air brake system pressure gauge shows at least 105 psi.

With the engine still off, apply the brakes fully for two minutes. The gauge reading drop should not exceed four psi in one minute.

With the engine still off, slowly open the draincocks in the trailer's air tanks and allow the pressure to drop gradually. The parking brakes should apply.

Remember that serious air losses are extremely hazardous conditions that are likely to cause accidents or breakdowns.

WARNING:

Do not operate this vehicle with any brake defects or with brakes out of adjustment.

CHECK BRAKE OPERATION

Before entering traffic, check the operation of the trailer brakes to be sure they are in good working order. Operate the foot pedal, dash control valves,

and hand valve to assure brake application and release in each instance. Listen for air leaks under each condition.

TIRES

WARNING:

Tire and wheel/rim servicing can be extremely dangerous and must be done only by trained personnel using proper tools and procedures. Information about tire and wheel servicing can be obtained from:

Do not over inflate. Check for proper inflation with an accurate gauge when the tires are cold. Check the spare too. Inspect tires for nails and other objects embedded in the rubber, and for stones and other objects lodged between duals. Examine tires to see that they are free of breaks and other defects. Watch new and retread tires for signs of failure during break-in period. Dual tires on any axle end should have the same diameter.

US Department of Labor
OSHA Publications Office
200 Constitution Ave. NW
Washington, DC 20210
1-800-321-OSHA (6742)

NHTSA
Vehicle Safety Hotline
1200 New Jersey Ave. SE
West Building
Washington, DC 20590
Toll Free: 1-866-327-4236

CAUTION:

Do not inflate tires above the maximum inflation pressure molded on the tire by the tire manufacturer. Tires must be matched with proper compatible rims for safe operation.

Replace any tire that has fabric exposed through the tread or sidewall, or that has less than **2/32"** tread depth.

TIRE LOADS

Do not overload the trailer tires. Overloading tires creates a dangerous, unsafe condition that should be avoided.

The total load per tire must not exceed the tire manufacturer's specified load carrying capacity at stated inflation pressures for both tires and rims. Great Dane, as required by the safety regulations of the National Highway Traffic Safety Administration, has assigned a Gross Axle Weight

Rating (GAWR) for each axle on the undercarriage. (See example certification plate below).

The GAWR and tire information shown on the vehicle certification plate was applicable at the time the trailer was manufactured. If the tires or other components of the running gear have been changed or altered since the trailer was manufactured, the GAWR may have changed.

GREAT DANE LIMITED PARTNERSHIP							
MANUFACTURED BY CHICAGO, IL							
GVWR	30844	KG	68000	LB	FG NUMBER	17152958	0001
GAWR ALL AXLES	9072	KG	20000	LB	WITH	295/75R 22.5 G	TIRES
AND	22.5 X 8.25	RIM AT	758	KPA	110	PSI COLD	
THIS VEHICLE CONFORMS TO ALL U.S. FEDERAL MOTOR VEHICLE SAFETY STANDARDS IN EFFECT ON THE DATE OF MANUFACTURE SHOWN BELOW							
TYPE	TRAILER		MODEL	CCC-9313-01053			
VIN	1GRAP062XHB712112		COUPLER HEIGHT	1.19	M	47.00	IN
			OVERALL HEIGHT	4.11	M	13	FT 6 IN
							
DATE OF MFG	MONTH	YEAR					
	10	11	12	2016			

SPARE TIRE

Tires and wheels are heavy. Use caution when handling.

When you need to use or replace the spare tire, move the trailer away from traffic to provide a solid, safe working area.

To remove the spare tire from the carrier, follow these steps:

1. Depress spring latch on hook (1). Disconnect hook (1) from free end of chain (2).
2. Pull chain off the tire and remove the tire from the tire carrier.

To replace the spare tire, follow these steps:

1. Slide the spare into the tire carrier as far as it will go. Be sure the tire size and the carrier are right for each other.
2. Run the chain through the center of the tire and wheel and back to the starting point. Pull the chain ends together as tight as possible.
3. Secure the chain by snapping hook (1) on the free end chain (2).

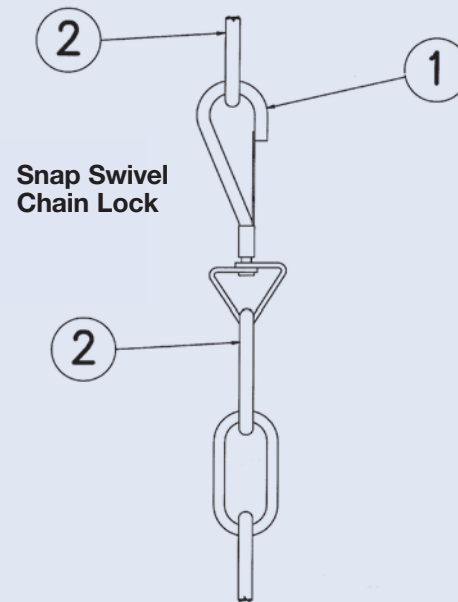

RIMS AND WHEELS

Proper installation of rims and wheels on a vehicle is essential to safe, economical, trouble-free service. Use only the specified sizes of studs and nuts.

Recommended installation procedure

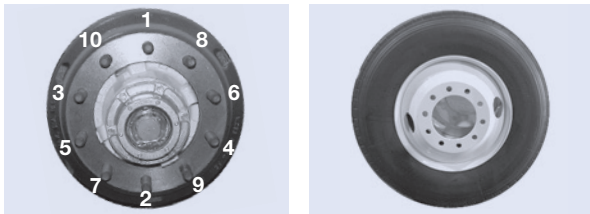

Disc Wheels

Check all parts for damage, including wheels. Insure that studs, nuts and mounting faces of hub and wheels are clean and free from grease. Replace any defective parts.

Mount single wheel or inner dual wheel (also, outer dual wheel for hub-type mounting) over studs, being careful not to damage stud threads. Draw up nuts alternately in the sequence as shown

above. Do not tighten them fully, however. This procedure will permit the uniform seating of nuts and insure the even face-to-face contact of wheels and hub.

Tighten nuts fully, using the same alternate sequence. Mount the outer wheel (for double cap mounting) and repeat the entire procedure. In each case, be sure to tighten wheel nuts only to the torque level recommended in the table below and to maintain them at that level through planned, periodic checks. Note: When inner cap nuts are retightened, be sure first to loosen outer cap nuts several turns; then, retighten them.

WARNING:

Do not intermix wheel types. Insufficient mounting torque can cause wheel shimmy, resulting in damage to parts and extreme tire tread wear. Excessive mounting torque can cause studs to break and discs to crack in the stud hole area.

WARNING

GREAT DANE LTD

PART NO. 42100753
SD83410

PREVENT WHEEL SEPARATION

RECOMMENDED TIGHTENING TORQUE FOR DISC WHEEL MOUNTING NUTS IS 450-500 LB-FT. APPLIES TO BALL-SEAT AND HUB-PILOT MOUNTING SYSTEMS WITH 3/4-16 OR M22 X 1.5 STUDS FOR ALUMINUM AND STEEL WHEELS. CHECK NUTS FREQUENTLY (50-100 MILES AFTER INITIAL IN-SERVICE DATE AND AT INTERVALS NOT TO EXCEED 25,000 MILES) AND TIGHTEN TO MAINTAIN RECOMMENDED TORQUE.

FAILURE TO HEED THIS WARNING CAN RESULT IN PROPERTY DAMAGE, SERIOUS INJURY OR DEATH.

***NOTE:** Rim and wheel nuts should be rechecked for proper torque after vehicle has been operated for 50-100 miles, and every 25,000 miles thereafter, as well as during regular maintenance checks.

LUBRICATION OF FLANGE NUTS & STUDS

To maintain the desired torque/tension relationship, it is necessary to renew the lubricant on the threads and between the nut body and flange. Relubrications should be done any time wheels are removed for tire repair or replacement, brake service, etc.



WARNING!

Be sure to keep nut flange face and wheel and drum surfaces (denoted by "X") free from lubricant, dirt or other foreign material.

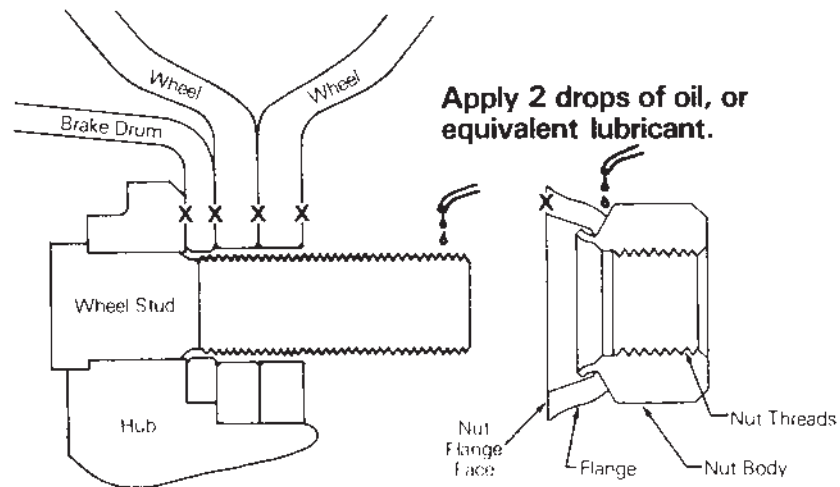

An excess of lubricant is not desirable. It will not improve nut performance, it makes the parts hard to handle, it will attract dirt, and it will cause an unsightly appearance of the wheel.

Use any lubricant commonly available to the shop—engine oil, WD-40™, anti-seize compound such as Permatex™ #133A, or spray lube such as Lubriplate™ Spray Lube 'A'. Never-Seez™, although not a lubricant, is also satisfactory.

NUT TIGHTENING PROCEDURE

A key to successful performance of the hub-piloted wheel, hub and drum mounting system is proper installation of the flange nuts. IT IS IMPORTANT to follow the recommended installation instructions, paying particular attention to the sequence of nut tightening.

- Before installing wheels, generously coat pilot pads with a non-water-based lubricant, and be sure that the drum is positioned on the raised step of the pilot pad. One of the hub's pilot pads should be at the top location. Adjustment of the brakes prior to installation of the wheels helps keep the drum in proper position.
- Lubricate the flange nuts and stud threads. Apply two drops of any common lubricant on the threads, and also in the crevice between the flange nuts body and its attached flange.
- After positioning wheels on pilot pads, hand start flange nuts. ALL nuts and studs have RIGHT HAND metric threads.
- Snug top nuts to about 50-100 lb-ft torque. Snug remaining nuts using pattern shown. STARTING AT THE TOP will help insure that the drum and wheels seal properly on their pilots.
- Check to be certain that the mating surfaces of the wheel(s) and drum are flush.
- Again, starting with the top nuts, tighten to 450-500 lb-ft using the pattern shown.

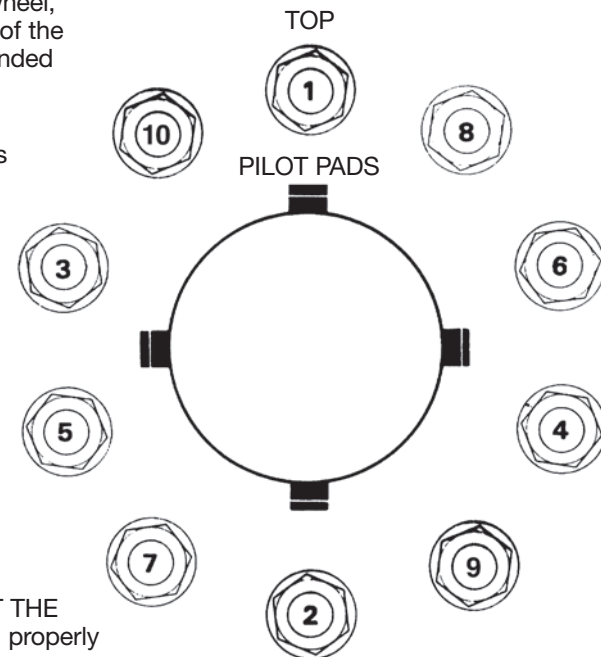

Rim and wheel inspection and maintenance

1. Check all metal surfaces thoroughly, including area between duals and on inboard side of wheel. Watch for:
 - a. Excessive rust or corrosion buildup
 - b. Cracks in metal
 - c. Bent flanges, resulting from road obstructions
 - d. Deep rim tool marks on rings or in gutter areas
 - e. Loose, missing or damaged nuts or clamps
 - f. Bent or stripped studs
 - g. Damaged or missing rim drive plates
 - h. Mismatched rim parts
2. Pull damaged rims or wheels.

WARNING:

Excessively corroded or cracked rims or rings can be dangerous. Deflate tires prior to the removal of rims or wheels from vehicle.

3. Mark damaged or hazardous areas so that part will be removed from service.
4. Replace damaged parts. Insure that replacements are made with the proper sizes and types of rims and rings.



5. Inflate tires only to recommended air pressures.

Rim and wheel maintenance during tire changes

Check all metal surfaces as in No. 1 above. A more thorough check may be made, however, after the tire has been demounted. Watch particularly for the damages illustrated on the next page and refer to recommendations in this section if corrective measures are required.

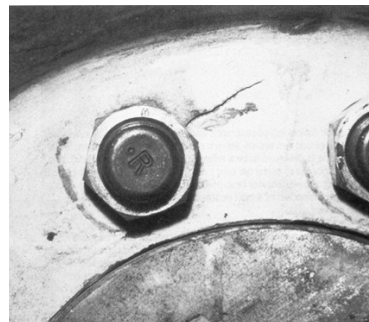

Cracks in the wheel disc, between stud holes or hand holes. These are caused by loose wheel nuts, improper installation procedures, and use of incorrect sizes or types of attaching parts.

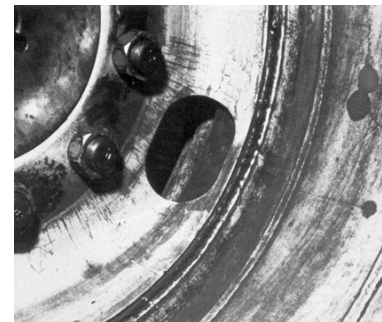

Cracks in the rim base, in the back flange and gutter areas. These are caused by deep rim marks, overloading and overinflating tires, and using larger than recommended tire sizes.



HUBS

⚠ WARNING: Cracked wheels, loose nuts, or missing studs are extremely hazardous conditions that are likely to cause accidents or breakdowns.

Check hub gaskets and seals for leaks before each trip. Leaking seals can result in ruined wheel bearings and possible failure of the axle-wheel assembly.

Check oil level in hubs before every trip. Add oil when low, only to the level indicated by mark on

the hub cap. Too much oil can damage the wheel bearings. Use a gear type oil: SAE 140 if temperature is above freezing. SAE 90 if temperature is below freezing, or a multipurpose oil with a SAE range of 85 to 140 for year round conditions.

Lubrication fill oil (static)

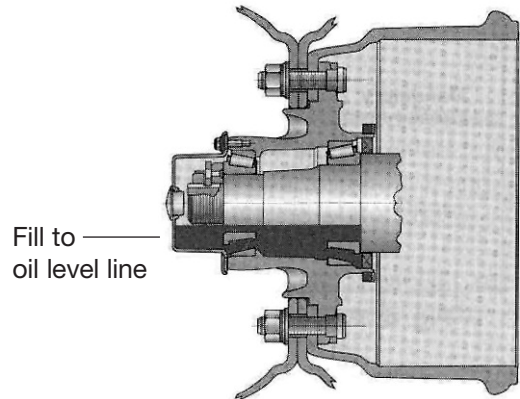

Lubrication fill semi-fluid grease (No. 00)

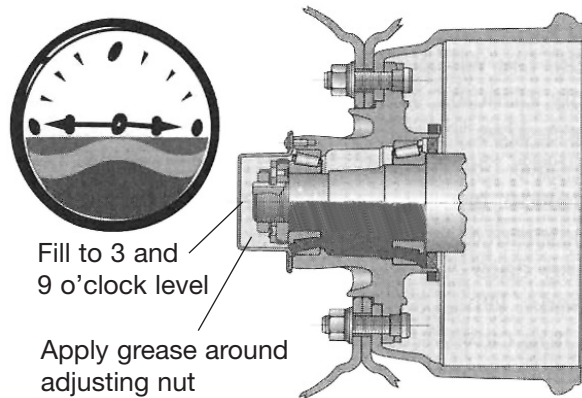

AXLE ALIGNMENT

Axle alignment must be checked at regular intervals. If the trailer is not tracking properly, this should be reported to the Maintenance Department.

LEAF-SPRING SUSPENSION

⚠ WARNING:

Broken spring leaves, missing or loose U-bolts, or other defective conditions likely to cause axle shift, are hazardous and can cause accidents or breakdowns

Check the equalizer to see that there are no obstructions to movement during operation. If equalizer movement is restricted by an obstruction, the axle "walk" will not be sufficient and damage will result.

Check wear pads in hangers. If they are wearing thin, install new wear pads or the spring will cause permanent damage to the hanger. Do not operate with broken spring leaves.

AIR-SPRING SUSPENSION

The air suspension height is controlled by height control valves that maintain a constant trailer height by pressurizing or exhausting air in the air springs as needed to support the load being carried.

You must build up and maintain your trailer's air pressure higher than 70 psi before operating the trailer. The air protection valve won't operate until you have 70 psi in the system. This valve automatically maintains a safe air brake pressure higher than 70 psi in the event of an air loss due to a failure in the suspension system.

If an air-spring failure occurs on one side, it is recommended to completely deflate the suspension and temporarily operate on the air springs' internal rubber bumpers to allow your trailer to be moved to a shop for repairs.

To deflate or cut off the air pressure to the damaged air spring, disconnect the height control valve actuating levers from their link assemblies and rotate to the vertical down position.

EXHAUST (DUMP) VALVE OPERATION

In many cases trailers that are equipped with air suspensions also incorporate valving that allows the suspensions' air pressure to be manually exhausted (dumped) for loading, unloading, or when the trailer is parked for a prolonged period of time. The following steps describe a typical sequence of operations involving the use of a pneumatically or electrically controlled exhaust (dump) valve:

To Exhaust

1. Pull the trailer forward past the loading dock.
2. Activate the exhaust valve using either the pneumatic or electric switch provided by the installer.
3. Back the trailer to the dock area, allowing the suspensions to exhaust as you move rearward.
4. Apply the trailer's parking brakes after the air pressure has completely exhausted, chock the trailer wheels and load/unload as you normally would.

(NOTE:) Lower the trailer support legs (landing gear) after applying the parking brakes if the tractor is to be uncoupled.

To Inflate

1. Couple the tractor and trailer.
2. Raise the support legs prior to inflating the suspension's air springs.
3. Un-chock the wheels, release the parking brakes and pull away from the dock.
4. Activate the exhaust (dump) valve using the pneumatic or electric switch.

The steps listed above will prevent the trailer from "walking" away from the dock during loading or unloading. To accomplish this, and to avoid damaging the trailer and suspension components, the following conditions must be met:

- The suspensions' air pressure must be exhausted BEFORE the brakes are applied.
- ALL of the trailer air suspensions must be exhausted.
- The suspensions must be properly inflated BEFORE the trailer is driven away.

Following the steps listed above will satisfy these conditions and ensure the safe operation of the trailer air suspensions.

SUPPORTS (LANDING GEAR)

1. Always raise support legs completely before moving the trailer.
2. Always engage the support operating handle. Do not depend on the retaining bolt to transfer the rotation from the crank handle to the gear shaft.
3. Always use chock blocks or lock trailer brakes when uncoupling or coupling tractor and trailer on the road or in the terminal area. Chock as required for unusual conditions.
4. Always place support feet on a plank for flotation to prevent sinking into soil or soft asphalt when a loaded trailer is uncoupled from a tractor.
5. Always lower supports to the ground before disconnecting the tractor from the trailer.
6. Always store the crank in the crank holder.

Never force landing gear supports beyond their normal raised or lowered positions.



PARKING BRAKES

All axles are equipped with air/spring actuators. Each actuator is separated into two units. The base unit applies the service brakes. The top unit contains a coil spring that must be compressed by air within the chamber to release the parking brakes. Loss of air pressure in the supply line to the brake chamber will automatically apply parking and/or emergency braking.

⚠ CAUTION:

Actuator plugs must remain in place when not being serviced. Plugs prevent contaminants from entering brake chamber.

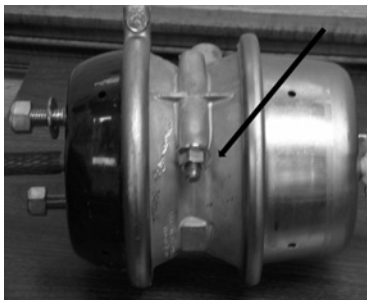

A manual release tool is provided on each actuator to allow release of the spring brake when sufficient air pressure is not available.

To manually release parking brake actuators:

1. Always position wheel chocks at both front and rear of tires before manually releasing parking brakes.
2. A parking brake release tool is stored in a pocket on the side of the brake chamber. (See photo).
3. Insert the detachable release bolt through hole in head. Turn the release bolt clockwise until it stops and locks, then pull the release bolt out as far as possible, and run the nut down, holding the bolt in place.

Using a hand wrench, turn the release bolt nut clockwise until the bolt extends about three inches. Make sure the release bolt is locked properly in the piston.

The parking brake coil spring is now caged.

⚠ CAUTION:

DO NOT operate your trailer with parking brakes caged or in any other way disabled. Never attempt to open a brake actuator. The internal spring is very dangerous.

ANTILOCK BRAKE SYSTEM

GREAT DANE LTD

⚠ WARNING

PART NO. 42100749
SD83830

PREVENT LOSS OF CONTROL

ABS MALFUNCTION INDICATOR LAMP SHOULD TURN ON AND OFF WHEN ELECTRICAL POWER IS INITIALLY APPLIED TO ANTILOCK BRAKE SYSTEM. IF LAMP DOES NOT TURN ON, IT MAY BE DEFECTIVE AND MUST BE REPAIRED IF LAMP TURNS ON AND REMAINS ON WHILE POWER IS APPLIED WITH TRAILER MOVING, SYSTEM MUST BE REPAIRED BY COMPETENT SERVICE FACILITY.

FAILURE TO HEED THIS WARNING CAN RESULT IN PROPERTY DAMAGE, SERIOUS INJURY OR DEATH.

REAR, SIDE AND VENT DOORS

1. Check rear, side, vent, and any accessory doors. Secure them open or closed as required.
2. Never have side or rear doors unlocked or open when the trailer is moving.

Swing Doors

CAUTION:

When you open side or rear doors, at all times apply an inward pressure on the door handle when releasing the handle from the gravity keeper. This may prevent a toppled load from snapping open the door handle, perhaps causing serious injury.

Overhead Doors

CAUTION:

When in operation, an overhead door is a large, heavy moving object. When the door is moving up or down, avoid standing in the opening or walking through the doorway.

To assure safe, reliable, and continuous operation, the following precautions and maintenance instructions must be observed.

1. Operate the door only when it is properly adjusted and free from obstruction.
2. Do not use any part of the door, such as the strap or lift handle, as an aid when entering or leaving the trailer.
3. Use caution when passing under a roll-up door with a lift truck.
4. Leave the door alone if it becomes difficult or impossible to operate. Have it repaired or adjusted by a qualified door repair person.
5. The door spring is constantly under extreme tension. Repairs and adjustments, especially to the door counterbalance assembly, are potentially dangerous and must be performed by qualified service personnel only.
6. Clear any obstruction from the door tracks and the base of the mounting angle where the door comes down to the floor.

7. Perform regular inspection and maintenance on the listed items:
 - a. Be certain that all nuts and bolts are tight and secure.
 - b. Check cables at attachment points and replace all frayed or otherwise damaged cable.
 - c. Check cable drums for tightness against bearings.
 - d. Check all rollers for smoothness of operation, and have all sliding or otherwise damaged rollers replaced.
 - e. Replace frayed, damaged, or severely worn pull straps.
 - f. Check the door lock to be sure that it is free, and fully operational.
 - g. Replace broken or damaged hinges.
 - h. Periodically use a light lubricant (not grease) on rollers, counterbalance hinges, and lock, as necessary, to maintain a smooth door operation.

CAUTION:

Close and lock overhead door before moving the trailer.

Bulkheads

CAUTION:

Do not operate the trailer with a bulkhead locked in the horizontal position. Do not use the bulkhead as a load shifting barrier or brace.



WARRANTY CLAIMS

First purchaser warranty claims and other consumer complaints should be reported in writing to:

Customer Service Department
Great Dane Limited Partnership
P.O. Box 67
Savannah, GA 31402-0067

or call 877-369-3493

REPORTING CLAIMS AND SAFETY DEFECTS

Customer Service Phone Number: 877-369-3493

This vehicle was designed and quality inspected to conform with industry standards, and all applicable National Highway Traffic Safety Administration (NHTSA) safety standards. Great Dane Limited Partnership warrants this vehicle to be free from defects in materials and workmanship when manufactured. If you detect a defect that could cause an accident, injury or death; or if you wish to report any such accident, injury or death, or any property damage claim or other complaint not addressed to the Customer Service Department, then you should in writing advise:

Director, Customer Service
Great Dane Limited Partnership
P.O. Box 67
Savannah, GA 31402-0067

If you believe that your vehicle has a defect which could cause a crash or could cause injury or death, you should immediately inform NHTSA in addition to notifying Great Dane Limited Partnership.

If NHTSA receives similar complaints, it may open an investigation, and if it finds that a safety defect exists in a group of vehicles, it may order a recall and remedy campaign. However, NHTSA cannot become involved in individual problems between you, your dealer, or Great Dane Limited Partnership.

To contact NHTSA, you may call the Vehicle Safety Hotline toll-free at 1-888-327-4236 (TTY: 1-800-424-9153); go to <http://www.safercar.gov>; or write to:

Administrator, NHTSA,
1200 New Jersey Ave. SE
West Building
Washington, DC 20590

You can also obtain information about motor vehicle safety from <http://www.safercar.gov>.



Great Dane

DRIVE AWAY WITH MORE

www.greatdanetrailers.com

Part No. 42101203

Great Dane and the oval are registered trademarks of Great Dane Limited Partnership.

683 DMD 0117