

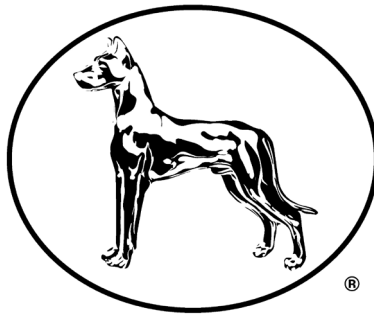

# MAINTENANCE MANUAL FOR VAN & PLATFORM TRAILERS

Please route to the individual responsible for trailer maintenance.

*Great Dane Trailers*  
SAVANNAH, GEORGIA

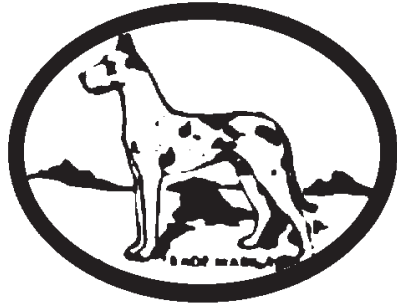

*Great Dane Trailers*



*Great Dane*



**GREAT DANE**



# MAINTENANCE MANUAL

## VANS

Reporting Safety Defects	2
Reporting Other Claims	2
Introduction	3
Maintenance Tips	4
Appearance Maintenance	5
Freezing Weather Maintenance	5
Suggested Preventive Maintenance	5
Electrical System	6
Brake Maintenance	7
Brake Care and Adjustment	8
Brake Adjusters	9
Parking Brakes	10
Brake Balance	10
Oil Seals and Hub Caps	11
Wheel Bearings	11
Suspensions	13
Running Gear Assembly	14
Servicing Rims and Wheels	14
Single-Piece Rim Wheels	15
Rim and Wheel Inspection and Maintenance	15
Rim and Wheel Problems	16
Tire Care	17
Axle Alignment	19
Upper Coupler and Kingpin	20
Pintle Hook	21
Support Gear	21
Rear Impact Guard	21
Side and Roof Panels - Vans	22
Rear Frame, Doors and Hardware	22
Entry and Exit	23
Floor System	23
Insulated Trailer Maintenance	23
Maintaining Insulation Efficiency	24
Safety Measures - Urethane Foam	24
Converter Dolly	25
Alterations to the Trailer	26

Bibliography

Appendix

27

28

## PLATFORMS

Reporting Safety Defects	2
Reporting Other Claims	2
Introduction	3
Maintenance Tips	4
Appearance Maintenance	5
Freezing Weather Maintenance	5
Suggested Preventive Maintenance	5
Electrical System	6
Brake Maintenance	7
Brake Care and Adjustment	8
Brake Adjusters	9
Parking Brakes	10
Brake Balance	10
Oil Seals and Hub Caps	11
Wheel Bearings	11
Suspensions	13
Running Gear Assembly	14
Servicing Rims and Wheels	14
Single-Piece Rim Wheels	15
Rim and Wheel Inspection and Maintenance	15
Rim and Wheel Problems	16
Tire Care	17
Axle Alignment	19
Upper Coupler and Kingpin	20
Pintle Hook	21
Support Gear	21
Rear Impact Guard	21
Floor System	23
Main Beams	25
Crossmembers	25
Extendable Platforms	25
Converter Dolly	25
Running Gear Assembly	26
Alterations to the Trailer	26





## **WARNING**

This safety alert symbol is used throughout this manual to indicate potential personal safety hazards. Failure to heed the warnings associated with the safety alert symbol can result in property damage, serious injury or death.

# REPORTING SAFETY DEFECTS AND OTHER CLAIMS

## Customer Service Phone Number: 877-369-3493

This vehicle was designed and quality inspected to conform with all applicable National Highway Traffic Safety Administration (NHTSA) safety standards. Great Dane Limited Partnership warrants this vehicle to be free from defects in materials and workmanship in accordance with its standard printed warranty (see Appendix). If you detect a defect that could cause an accident, injury or death; or if you wish to report any such accident, injury or death, or any property damage claim or other complaint not addressed to the Customer Service Department, then you should in writing advise:

Director, Customer Service  
Great Dane Limited Partnership  
P.O. Box 67  
Savannah, GA 31402-0067

If you believe that your vehicle has a defect which could cause a crash or could cause injury or death, you should immediately inform NHTSA in addition to notifying Great Dane Limited Partnership.

If NHTSA receives similar complaints, it may open an investigation, and if it finds that a safety defect exists in a group of vehicles, it may order a recall and remedy campaign. However, NHTSA cannot become involved in individual problems between you, your dealer, or Great Dane Limited Partnership.

To contact NHTSA, you may call the Vehicle Safety Hotline toll-free at 1-888-327-4236 (TTY: 1-800-424-9153); go to <http://www.safercar.gov>; or write to:

Administrator, NHTSA,  
1200 New Jersey Avenue, SE West Building  
Washington, DC 20590.

You can also obtain other information about motor vehicle safety from <http://www.safercar.gov>.



# INTRODUCTION

This manual has been prepared to assist you in retaining the safety, dependability, and performance that are built into Great Dane trailers. It is essential that this trailer receives periodic inspections, maintenance, and service parts replacement. Maintenance should be performed by Great Dane branches and dealers, or other qualified service outlets that regularly provide such service. The Great Dane Operator's Manual covers pre-trip inspections, safety and maintenance checks, and other helpful information regarding Great Dane trailers.

If you have questions about this manual or its instructions, contact Great Dane Trailers Customer Service Department for answers. It is important that every trailer owner and/or operator have an organized Trailer Preventive Maintenance (TPM) program. The United States Department of Transportation requires that the maintenance records be kept on every commercial highway vehicle. It is to your advantage to be able to show that regularly scheduled TPM inspection checks have been made on every piece of equipment operated. A regular TPM program will assure that you get the most from your Great Dane trailer.

## SAFETY PRECAUTIONS

Before performing any maintenance or repair work which requires raising the vehicle, ensure the vehicle is properly supported with lift stands of sufficient rating capacity. Do not rely on jacks alone for support of the vehicle.

Safety glasses and hard hats should be worn when repairing and maintaining this vehicle.

### *A serious or fatal injury can occur...*

- A. If you lack proper training.
- B. If you fail to follow proper safe procedures.
- C. If you do not use proper tools and safety equipment.
- D. If you fail to use compatible replacement components.

## NOTICE

It is recommended that all necessary replacement components be from the original equipment manufacturers to insure proper fit and to maintain the structural capability built into your vehicle.

*The Great Dane Operator's Manual*, included with every new trailer, will give specific information about the following subjects:

- Gross Axle Weight Rating (GAWR)
- Gross Vehicle Weight Rating (GVWR)
- Cargo Capacity
- Proper Loading & Weight Distribution

Information shown in this Maintenance Manual is general information for maintenance and preventive maintenance of your Great Dane trailer. It is strongly recommended that you obtain specific maintenance instructions provided by the manufacturers of the components specified on this trailer. Refer to the bibliography in the back of this manual.

# MAINTENANCE TIPS

## **BREAKING-IN A NEW TRAILER**

The most critical time in a new trailer's life is its initial in-service check and first month's "shakedown." Preventive maintenance mechanics should be alert for under-inflated tires and threaded fasteners that may have loosened from factory-torque settings. Fastener torque should be all-inclusive and include refrigeration units, tanks, steps, carriers, etc.

Following are several areas that deserve particularly close attention during the first 30 days of a van or platform trailer's service life. Of course, your operation's maintenance records should reflect all areas which need to be closely checked.

## **TIRES**

While a new trailer's tires were correctly inflated when they were mounted at the factory, tire pressure is related to ambient temperature at inflation time. If a new trailer had tires mounted in a 70° F. ambient environment but was put in service in 20° F. weather, the tires may have lost as much as 10 psi for every drop of 20° F. in ambient temperatures below 50° F. Therefore, all tire pressures should be verified with an air gauge and rechecked each time the tractor refuels.

## **WHEELS**

Smaller fleets commonly overlook the need to retighten new-trailer-wheel lug nuts after the first 50 to 100 mi. of service on the initial "in-service." Retightening compensates for "normal" clamp force lost due to "seating in" of new materials. Tests have shown new-trailer-wheel lug nuts lose 250 lb-ft, or about half of their original torque value, during a short period of initial service. Unless those nuts are retightened to spec, additional clamping force will be lost, and damage to components will occur. Re-tightening during the initial in-service prevents wheel and stud damage. Thereafter, lug nuts should be checked every 25,000 mi.

## **LEAF-SPRING SUSPENSIONS**

All tandem axles are aligned when new trailers leave the factory. However, suspension fasteners may sometimes loosen, possibly causing alignment settings to change, and that can translate into possible erratic ride or accelerated tire wear. Therefore, at the first TPM interval, all suspension-system fasteners should be rechecked for correct torque value.

When tightening suspension-system fasteners, mechanics must tighten the "nut side" of torque-arm bolts. Tightening bolt heads does not produce the correct clamping force on the fastener.

It is also important to keep U-bolts, as well as torque-arm bolts, tight. Loose U-bolts allow trailer axles to shift, and even minor shifting during braking can cause control problems, excessive tire wear, or even broken spring leaves.

When U-bolts are torqued to proper specs, leaf-spring main leaves remain in proper contact with wear pads, with no "twists." Spring wear-pad contact will then be even, too.

Also, at the first TPM, a trailer mechanic should take the time to verify that there are no obstructions to the movement of the suspension equalizers.

When the mechanic has made sure all fasteners are tight, he should use the 50-ft.-tape method, with axle extenders, to verify that the trailer tandem is, indeed, properly aligned. Remember: the longer the trailer, the more critical tandem alignment is to long tire life.

## **AIR-SPRING SUSPENSIONS**

Loose U-bolts in an air-spring suspension can cause a new trailer to roll and sway. Usually, a driver is quick to report this condition. The mechanic should make doubly sure that trailer-suspension fasteners, including U-bolts, are properly tightened.

Excessive play in an air-spring suspension's front-pivot connection is another cause of premature tire wear and erratic handling. Again, connection bolts, which may have loosened during the first weeks of service, may produce such handling problems. If not retightened, these loose bolts can cause rubber bushing wear.

## **SLIDING-TANDEM OPERATION**

A driver learning to handle a new trailer equipped with a sliding tandem should be sure he knows exactly how to use the stop-selector bar. He should also make sure that all four slider lock pins are set in place before operating the trailer, otherwise, the tandem may not be "locked," and a sudden brake application could force the slider rearward, causing damage to the tandem and trailer.

## **AIR SYSTEM AND BRAKE OPERATION**

During the first month's operation, a certain amount of "burnishing in" of brake lining occurs. This is normal and may result in some adjustment loss. Because out-of-adjustment trailer brakes mean increased stopping distance, plus an increased potential for jackknifing under certain conditions, trailer brake adjustment should be checked at the first TPM inspection. During routine maintenance, the dust cover cap on air chambers must be inspected to assure that is in place and sealing properly.

## **ANNUAL FHWA INSPECTION**

It is the carriers' responsibility to make sure that the vehicles operated by them are inspected and maintained under this Federal requirement.

During this inspection, make sure the upper slide rail to crossmember welds, pintle hook assemblies, safety equipment, etc. are inspected and corrected as required.

## **DOORS**

Almost invariably, a new trailer's hinged-type doors are difficult to latch. Drivers should expect to use extra muscle to secure doors until seals seat, but drivers should not use bars or some other device to force doors shut. It is equally important not to make adjustments to a new trailer's door latches or hinges to "correct" door closing. This will result in poor sealing later on.

# APPEARANCE MAINTENANCE

Appearance maintenance includes cleaning, polishing, corrosion prevention and removal, and protective coatings. You must have a working knowledge of each for the complete and proper appearance maintenance of a Great Dane trailer.

## WASHING AND CHEMICALS

Improper use of chemical cleaners has caused many a newly delivered trailer's finish to streak and fade, particularly yellow, red, and black models. Ironically, fade is often caused by a desire to keep the units clean—and using too strong a chemical solution. When instructions call for a 150:1 water/chemical ratio, do not use a 50:1 ratio. Sometimes fading caused by an overly concentrated caustic agent may be remedied with warm water rinsing and application of a glazing wax.

## APPEARANCE MAINTENANCE MATERIALS

Many chemical companies compound materials for appearance maintenance, and most provide instructions. Protective films, such as paints and clear coats, are necessary for the prevention of corrosion and the preservation of metal and wood surfaces. They add color, beauty, and distinction.

**NOTICE:** Aluminum brighteners should not be used.

Trailer undercoat materials can lose effectiveness if steam cleaned or if they come in contact with most solvents.

The underside, including beams, has been undercoated with a special, soft, rust-preventive coating. To prolong the life of this coating, avoid the use of high-pressure washers, strong cleaning solutions, and brighteners.

Due to the normal weathering and abrasion caused by road conditions, this coating must be inspected and recoated as necessary (approximately every 24 months).

Dry-freight laminated wood floors should be cleaned by sweeping and should not be washed out.

## BENEFITS OF APPEARANCE MAINTENANCE

Complete and proper appearance maintenance of Great Dane trailers not only adds to their physical condition and ultimate trade-in value but also favorably affects the operator's feelings about himself and his company. It also favorably affects the public image of the company.

# FREEZING WEATHER MAINTENANCE

Winter cold weather and its slush, sleet, and snow present special problems to the truck trailer operator and to maintenance men. Low temperatures can mean frozen and sluggish or inoperative brakes, sagging light and brake lines, broken connections, increased corrosion, and can require the installation of winter equipment.

Enclosed air systems for brakes and air-operated equipment should be drained regularly of accumulated moisture. The air tanks should be drained daily. The trailer air system should be treated through tractor equipment only. Use of additives can cause damage to the brake system. This could result in metal corrosion or swelling of brake valve seals. Make sure electrical and brake lines are adequately supported.

Ice and mud accumulations on brake lines and actuators should be removed regularly. Any air leaks that may exist are difficult to find when they are encased in ice and mud.

## WARNING

Do not use heat on any part of the air system.  
The use of heat can cause a rupture and can be very dangerous.

## WINTER CORROSION MAINTENANCE

Magnesium and calcium chlorides used to control snow and ice on many highways, if not properly cleaned from your tractor and trailer equipment after each trip, will result in rust and corrosion damage in as little as one winter of operation.

Information concerning corrosion maintenance can be found in the publication's bibliography and on Great Dane's website, [www.greatdanetrailers.com](http://www.greatdanetrailers.com).

### These references outline:

1. What states use these chemicals
2. How these chemicals affect equipment operated over road surfaces treated with it.
3. What you should do to protect and maintain your equipment when it's exposed to these highly corrosive chemicals.

## SUGGESTED PREVENTIVE MAINTENANCE

### EVERY 1,000 MILES:

- Check oil level in wheel hub and inspect wheel hub for leaks

### 15,000 MILES OR MINIMUM OF TWICE A YEAR:

- Check brake adjustment
- Check and repack wheel bearings as required once per year or every 100,000 miles as recommended by the T.M.C.

### 25,000 to 30,000 MILES:

- Check lining wear and estimate reline time
- Inspect camshaft, camshaft spider bushing and camshaft support bracket bushing for any signs of wear
- Lubricate brake actuating components

### 100,000 MILES, ONCE A YEAR, OR AT BRAKE RELINE:

- Replace wheel bearing lubricating oil (if applicable)
- Check brake air actuators and adjusters
- Inspect brake rollers, roller shafts, anchor pins and bushings and replace if necessary



# ELECTRICAL SYSTEM

## ⚠ CAUTION

### CONNECTOR WIRING CHANGE

#### NOTICE TO ALL TRACTOR-TRAILER OWNERS AND USERS

Federal Motor Vehicle Safety Standard No. 121, Air Brake Systems, was amended by the National Highway Traffic Safety Administration of DOT to require that truck tractors manufactured on or after March 1, 1997, provide constant power for a trailer's antilock brake system (ABS). Some manufacturers provided this feature before the effective date.

These tractors using a single 7-way electrical connector will have constant power for ABS on the center pin when the key switch is on. Tractor-trailer owners and users who presently use the center pin for auxiliary power to equipment other than trailer ABS (for example, dome lights, backing lights, bottom dumps, sliding undercarriages, air ride dump valves, etc.) will be affected by this change.

In certain uses of this constantly powered center pin connector, unexpected or unintended activation of this equipment may be hazardous or result in personal injury.

BEFORE connecting your trailer to a tractor, MAKE SURE that the constantly powered center pin WILL NOT UNINTENTIONALLY TURN ON TRAILER EQUIPMENT. If you have any questions about your present wiring, or how to rewire your vehicles, you should contact the tractor manufacturer, auxiliary equipment manufacturer, and/or Great Dane Trailers Customer Service Department.

The electrical system on every Great Dane trailer meets or exceeds all federal and state requirements in effect at the time of manufacture. Wherever required by law, lamps and reflectors are marked by the manufacturer to indicate the appropriate specification with which each complies. For optimum performance and long life from the trailer's lamps and wiring, follow this inspection procedure. Clean all reflective tape or devices and lamps. See that all lamps burn properly. Replace all burned-out lamps and broken or missing reflective devices. Factory approved replacement parts should be used, and replacement bulbs or lamps of equal candlepower should be used for safety.

## ⚠ WARNING

TRAILER IS EQUIPPED WITH ANTILOCK BRAKE SYSTEM (ABS). NO. 7 (BLUE) CIRCUIT IS RESERVED FOR CONTINUOUS POWER SUPPLY TO ABS. FOR MOST EFFECTIVE ABS OPERATION, TOWING VEHICLE MUST SUPPLY MINIMUM OF 10 AMPS AT 12.5 VOLTS TO NO. 4 (RED) & NO. 7 (BLUE) CIRCUITS.

#### PIN COLOR CIRCUIT

1	WHITE	GROUND RETURN TO TOWING VEHICLE
2	BLACK	CLEARANCE, SIDE MARKER & ID LAMPS
3	YELLOW	LEFT TURN SIGNAL & HAZARD LAMPS
4	RED	STOP LAMPS & ABS POWER
5	GREEN	RIGHT TURN SIGNAL & HAZARD LAMPS
6	BROWN	TAIL, LICENSE, CLEARANCE & SIDE MARKER LAMPS
7	BLUE	ABS CONTINUOUS SHARED POWER



**FAILURE TO HEED THIS WARNING CAN RESULT IN PROPERTY DAMAGE, SERIOUS INJURY OR DEATH.**

**NOTE:** Electrical circuits may be protected by circuit breakers located inside the front nose box.

## WIRING DIAGRAM

- TOP VIEW OF TRAILER -

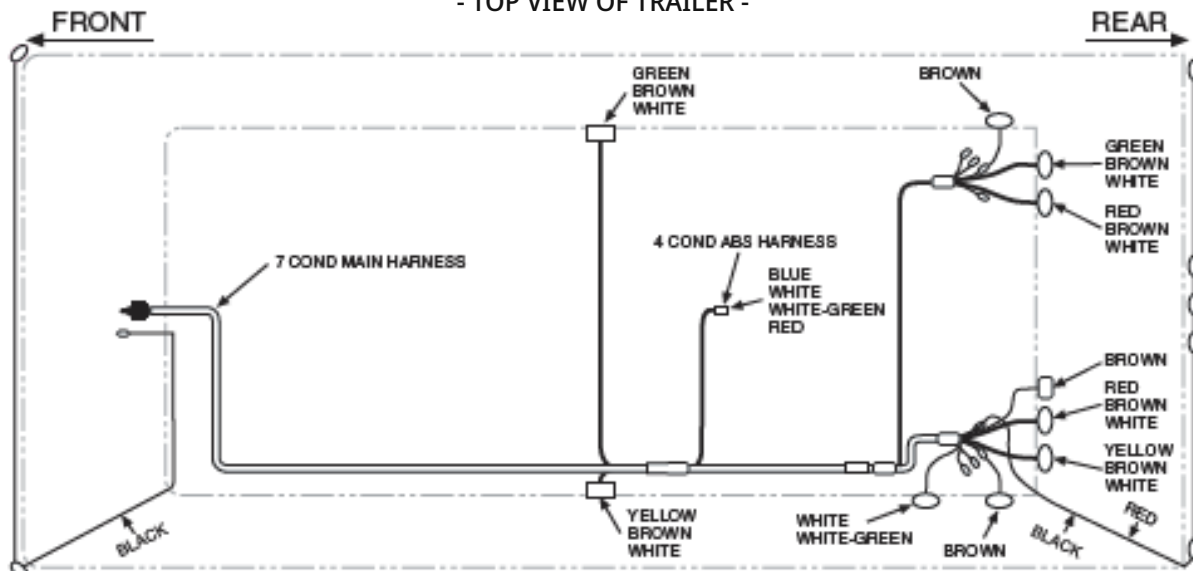

A warning decal, as shown on the previous page, is located on the front of each trailer. You may trace individual electrical circuits by the wire colors indicated. Refer to the schematic drawing and the decal for conductor numbers and wire colors.

### **WARNING**

Do not exceed 21 candlepower bulbs for dome lamps. Stronger bulbs may generate excessive heat and start a cargo fire. Cargo must be kept away from dome lamps. Dome lamps must be turned off for over-the-road operation.

Use only a 12-volt DC battery for checking lamps or antilock brake systems. Never use battery chargers or transformers.

Inspect all wiring to see that it is not damaged, and that it is properly supported and protected, with all connections tight. Frayed or damaged wiring should be replaced with stranded cable of equal size or larger, and should never be replaced with a smaller cable, or with a solid conductor. All holes where wiring passes through must contain rubber grommets.

**NOTICE:** Most trailers are equipped with a sealed wiring harness. Check the circuits at the plugs only – do not cut or probe test for shorts. Every time the harness is unplugged, repack connector with Grafo 112X grease or equivalent.

Never replace fuses or breakers with metal foil or other devices.

## BREAK MAINTENANCE

### DISC BRAKE SCHEDULED MAINTENANCE

Several different brands of disc brakes are available in the marketplace. Because procedures differ brand to brand, refer to the maintenance and adjustment information from the manufacturer of the specific brake in question.

### DRUM BRAKE SCHEDULED MAINTENANCE

Establish a preventive maintenance schedule for the periodic adjustment, cleaning, inspection, and lubrication of brake equipment on the basis of past experience and expected severity of operations. Take into account that linings and drums are particularly subject to wear and should not be allowed to wear to the point where rivets or bolts may contact brake drums. To compensate for this, schedule brake inspections as frequently as required to maintain satisfactory operation and maximum safety (not to exceed 25,000 miles). Accepted maintenance practices require that bearings should be adjusted properly before making brake adjustments; that adjustments provide uniform lining clearance, correct travel of levers, and proper equalization; and that brakes should be cleaned, inspected, lubricated, and adjusted each time the hubs are removed.

### MAINTENANCE DURING MAJOR OVERHAUL OF BRAKES

During a major overhaul, check the following parts and replace them with original equipment parts or equal, as required:

1. Spiders – for looseness or sheared fasteners.
2. Anchor pins – for wear or misalignment.
3. Brake shoes – for wear at anchor pin holes.
4. Cam shafts and cam shaft bearings or bushings –for wear.
5. Shoe-return springs – replace during overhaul and when you replace lining. Do not reuse springs.
6. Brake linings – for oil or grease saturation, wear, loose rivets or bolts.
7. Drums – or cracks, scoring, othe damage.

Install all new lock rings where they are used.

During a major overhaul, before reassembling parts that have been inspected, lightly coat cam shaft bushings and cam roller follower shafts and journals with brake lubricant.

### **WARNING**

Brake liners contaminated with lubricant cannot be salvaged or cleaned. They must be replaced.

For all fittings on cam shafts, meter-type fittings that have a maximum of 40 psi pressure relief or shutoff are recommended.

### BRAKE LUBRICANTS

A high-temperature waterproof grease in a number 1 NLGI grade to lubricate the brake actuating system is recommended. It should be smooth textured, corrosion resistant, and free of fillers and abrasives. It should maintain a satisfactory softness under normal parking and storage temperatures so the brakes can be applied and released.

The following greases meet these recommendations:

1. Texaco Thermotex EP #1
2. Shell Darina #1
3. Sunaplex #1 EP
4. Marathon 528 HD
5. Amdex #1 EP
6. Philube B #1

Trailers operating in extremely cold weather (below -40° F) may require a grease conforming to MIL-G-25013C.

# BRAKE CARE AND ADJUSTMENT

The trailer brake system will perform safely and efficiently only as long as it is properly maintained and not abused. Trailer brakes should be inspected frequently in connection with a Trailer Preventive Maintenance (TPM) Program. Out-of-adjustment brakes can cause increased stopping distance, shorter brake component life, and a greater tendency for the trailer to jackknife.

## WARNING

**Prior to performing maintenance on any air brake system component, chock the wheels. The system air pressure should be exhausted by opening the reservoir drain cocks.**

### AIR SYSTEM AND BRAKE OPERATION

Proper operation of the brake systems requires a firm seal between the air brake couplers. Inspect the couplers for seal damage and cracked housings. Some couplers are equipped with filters. These filters must be cleaned at regular intervals to prevent malfunction of the brake systems. Inspect the air hoses for cracking and for frayed connections. Be sure air hoses are not rubbing on any metal surface or each other. Replace or repair damaged components.

Keep the air system clean. All air tanks should be drained daily to remove moisture and other contaminants. See Freezing Weather Maintenance.

Some air valve manufacturers discourage the use of air line antifreeze. Use may result in deterioration of seals in these valves.

If you use Teflon tape or other thread sealers to seal threaded connections in your air lines, be careful not to allow pieces of the sealer to enter the air system. It can clog passages into the valves and cause them to malfunction.

Keep the air system tight. The air system cannot be charged properly if there are leaks in reservoirs, lines, hoses, or valves. Always check the tractor pressure gauge for unusual drops or extended buildup times.

Run the tractor engine until the air brake system pressure gauge shows at least 105 psi. Listen for air leaks.

With the engine off, check the gauge reading with no brakes applied. The gauge reading loss should not exceed three psi in one minute.

With the engine still off, apply the brakes fully for two minutes. The gauge reading drop should not exceed four psi in one minute. With the engine still off, slowly open drain cocks in the trailer's air tanks and allow the pressure to drop gradually. In a system employing spring brake control valves, the spring brakes should function and apply the brakes.

In a system that does not employ spring brake control valves, the relay emergency valve should function and apply the brakes.

## WARNING

**Serious air leaks in the trailer's braking system are hazardous conditions that require the trailer to be placed out of service until they are properly corrected.**

A schedule for periodic cleaning, inspection, adjustment, and lubrication of brake equipment should be established by the operator, based on past experience and severity of operation.

### BRAKE SHOES

Brake shoe designs vary, depending on the type of brake and brake manufacturer. Some brakes require special tools. If you have problems removing brake shoes, refer to the brake manufacturer's manual.

### BRAKE SHOE SPRINGS

Replace weak or unmated brake shoe springs whenever they cause pulling or dragging brakes. The springs are constantly expanding and contracting in the confined hot area of the brake drums. Excessive heat during expansion will cause them to weaken.

### BRAKE LINERS

The certified Gross Axle Weight Rating (GAWR) in many cases is determined by the friction level of the brake liners. The friction level is determined by the axle and vehicle manufacturer to provide the required brake torque as prescribed by governmental regulations.

**NOTICE: When replacing liners, be sure to use liners with the same friction level as those removed from the trailer so that the GAWR is not reduced.**

### REFACING DRUM

It is not a good practice to reface brake drums. Refacing can weaken the drums, making them unable to dissipate all the heat generated by brake applications, and making them susceptible to distortion and heat cracks.

If brake drums must be refaced on cam-type brakes, when oversized linings are used, precautions regarding cam travel should be checked to prevent sticking cams or cam rollover. This problem often exists when the linings become worn. It may be necessary to install oversized rollers to prevent this problem.



## OVERSIZE LINERS

To compensate for material removed when refacing brake drums, X (1/16" oversize) and XX (1/8" oversize) liners are furnished by the lining manufacturers. When oversize liners are used, the drums should be machined in increments of 1/16" (radius increased 1/16").

### WARNING

Enlarging the drum diameter may permit the cam to rotate beyond its maximum lift when the lining becomes worn. This can result in sticking cams or cam rollover.

To avoid this condition and to obtain maximum lining wear, oversize roller cam followers or wear plate shims (depending on the brake design) should be installed when the liners become approximately 50% worn.

## BRAKE SHOE ROLLER CAM FOLLOWERS

Roller cam followers are available in four sizes, each having been designed for a specific purpose.

### STANDARD SIZE (1.250")

Standard rollers are used when installing standard lining with standard drums, X lining with 1/16" oversize drums, or XX lining with 1/8" oversize drums.

If the drums have been refaced and oversize rollers later installed, the oversize rollers must be removed and standard rollers installed when the new liners are installed.

### 1/8" OVERSIZE (1.375")

Use 1/8" oversize cam followers when you install standard liners with worn or trued drums that are 1/32" oversize. Circle grind the liners a few thousandths less than the drum diameter.

### 1/4" OVERSIZE (1.500")

Use 1/4" oversize cam followers when X liners have been installed with 1/16" oversize drums and standard rollers. The standard rollers should be removed and 1/4" oversize installed before the lining becomes worn to the point when the brake cam is no longer effective.

### 1/2" OVERSIZE (1.750")

Use 1/2" oversize cam followers when XX liners and 1/8" oversize drums have been used. The standard rollers should be removed when the liners become approximately 50% worn, and 1/2" oversize rollers should be installed.

## CAM PLATE SHIMS

When standard liners are installed with worn or trued drums, or when X or XX liners have been installed and are approximately 50% worn, shims or a combination of shims should be installed under each of the cam wear plates to permit the cam to be returned to the full release position. Shims are available in 1/64", 1/32" and 1/16" thicknesses.

## BRAKE DUST SHIELDS

The brake spiders used for mounting the brake shoe assembly parts also become the mounting for optional dust shields.

The use of dust shields should be determined by conditions encountered by the trailer. Operations in mud, sand, dirt, water, and other forms of foreign materials should be the governing factors. When these conditions exist during winter months and maximum cooling is desirable during summer months, dust shields are easily installed or removed.

**NOTICE:** Failure to use dust shields during months where gravel chips, etc., are used on roads may allow drums to be scored by these materials. Dust shields may provide the desired protection.

# BRAKE ADJUSTERS

## AUTOMATIC ADJUSTERS

Several different brands of automatic adjusters are common. Because adjustment differs, refer to the maintenance and adjustment information from the manufacturer.

Some automatic slacks are equipped with an adjustment pawl which eliminates loss of adjustment. This pawl must be removed prior to backing off on the adjustment to prevent damage to the splined pawl and adjusting screw.

**NOTICE:** Automatic adjusters may seem to be over-adjusting and may seem to be more sensitive until brakes are properly burnished.

# PARKING BRAKES

All axles (except some converter dolly axles) are equipped with air/spring actuators. Each actuator is separated into two units. The base unit applies the service brakes. The top unit contains a coil spring that must be compressed by air within the chamber to release the parking brakes. Loss of air pressure in the supply line to the brake chamber will automatically apply parking and/or emergency braking.

In case of a service brake system air failure, when the spring brakes are applied in an emergency stop, a spring brake air reservoir retains enough stored air to release the spring brakes at least once by means of the tractor parking brake control.

In the absence of air pressure, a manual release is provided to allow release of the spring brake (see following instructions).

To manually release parking brake actuators:

1. Always position wheel chocks at both front and rear of tires before manually releasing parking brakes.
2. A parking brake release tool may be stored in a pocket on the side of the brake chamber. (See photo.)

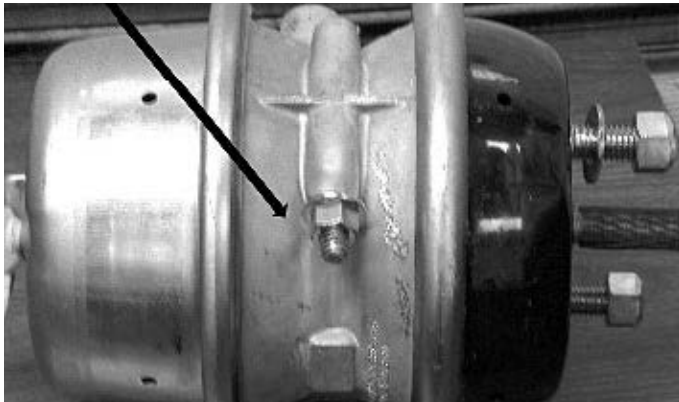

3. Insert the detachable release bolt through hole in head. Turn the release bolt clockwise until it stops and locks, then pull the release bolt out as far as possible, and run the nut down, holding the bolt in place.

Using a hand wrench, turn the release bolt nut clockwise until the bolt extends about three inches. Make sure the release bolt is locked properly in the piston.

The parking brake coil spring is now caged.

## ⚠ DANGER

**DO NOT operate your trailer with parking brakes caged or in any other way disabled.**

Never attempt to open a brake actuator. The internal spring is very dangerous. Do not repair spring brakes. Discard only by using proper, approved procedures. If this procedure is not known, contact the actuator manufacturer or Great Dane Trailers before removing the actuator from the trailer. Never operate the trailer with the end-cover cap removed.

## ⚠ WARNING

FMVSS-121 revisions made mandatory 10-8-92 require air system supply lines to be protected to at least 70 psi. The 70 psi (multifunction) emergency air valves require that tractor air compressor governors be set at 105 psi (minimum) to assure full release of the trailer parking brakes.

# BRAKE BALANCE

Differences in crack pressures on hold-off valves on tractors and trailers can lead to air pressure imbalances that cause the trailer brakes to do a majority of the braking. Another contributing factor to premature trailer brake wear is torque imbalances created by differences in brake linings.

These imbalances can lead to greatly reduced trailer brake lining life, trailer brake drum heat checking, heat cracking, and breakage.

The air pressure imbalance typically ranges from 4 to 6 psi between the tractor and trailer. The trailer industry has been using 4 to 5 psi crack-pressure air valve systems and tractor manufacturers in some cases are using 8 to 10 psi hold-off valves.

This imbalance will cause the trailer to do nearly all the braking in low-air pressure applications. And because most normal braking is done at

air pressure applications of 10 to 15 psi, this means that routinely, the trailer brakes are the ones that are stopping the vehicle in all but the hardest braking.

One simple way to see if an imbalance situation exists is to use a duplex gauge that measures air pressures at the coupler and the actuator air chamber. This will show if there is an imbalance situation between the tractor and the trailer.

Another method is to use a special balance kit such as the ones available from the major brake manufacturers. The balance kits include gauges to check air pressures in the trailer chambers, the tractor chambers and at the coupler, and electronically compares them. Industry standards recommend the tractor and trailer should be within 1 and 2 psi.

This detailed check takes about two and one-half hours. It's important to check a representative tractor and trailer each time you order equipment.

Keeping an eye on your brake service records will also flag imbalance problems. If you are seeing 300,000 miles on tractor linings and 70,000 miles on trailer linings, there's obviously an imbalance problem.

## OIL SEALS AND HUB CAPS

### OIL SEALS

Oil seals vary in design and installation. Refer to the seal manufacturer's manual for proper installation with proper tool.

To insure leak-free operation replace oil seals each time you remove a hub. Never reuse seals, even if they show no signs of leakage.

### HUB CAP INSTALLATION

1. Clean the hub cap and the face of the hub.
2. Position the gasket.

**NOTICE:** Never reuse a gasket.

3. Install the hub cap. If you are installing a transparent hub cap, install the reinforcing ring on the out-side. Install the capscrews and lockwashers. When installing a transparent hub cap, do not tighten to exceed 15 lb-ft torque.
4. Remove the fill plug and pour oil to the level specified on the cap. Allow sufficient time for the oil to seep into the hub cavity and recheck.

## WHEEL BEARINGS

### ADJUSTMENT

For maximum bearing life, adjust and lubricate bearings properly at regular intervals depending upon trailer speeds, loads, and general operating conditions.

1. Clean bearings, hub, and seals.
2. Replace any worn or damaged parts.
3. Pack hub and bearings with specified lubricant.
4. Assemble bearings and hub on axle sleeve.
5. Install thrust washer if used.
6. Install wheel bearing adjusting nut. Thread nut against bearing or thrust washer as you rotate wheel. Be sure there is sufficient clearance between brake shoe and drum so brake shoe drag will not interfere with bearing adjustment.
7. Tighten adjusting nut to 50 lb-ft torque while you rotate hub
- 8a. For axles that have single-nut construction, back off in both adjusting nut 1/8 to 1/6 turn. Cotter pin (or lock) nut in place.
- 8b. For axles that have double-nut lock construction, back off adjusting nut 1/6 to 1/4 turn. Assemble wheel bearing nut lockwasher.

A) For assemblies using a bending type lockwasher tighten jam nut with torque wrench as follows:

Nut Size	Torque Lb-Ft	
	Minimum	Maximum
1-1/8" to 2-5/8" 2	100	150
2-5/8" and over	100	200

Bend lockwasher over both adjusting and jam nuts to complete the assembly.

B) For assemblies using a dowelled adjusting nut and pierced lockwasher, tighten jam nut with a torque wrench as follows:

Nut Size	Torque Lb-Ft	
	Minimum	Maximum
1-1/8" to 2-5/8" 2	200	300
2-5/8" and over	250	400

9. For single nuts with lock features built into the nut (ie. Pro Torque, Axilok), refer to the vendor maintenance manual.
10. Keep the resulting end play within limits of .001" to .003".

**NOTICE:** Remove the set screw lock device in the serrated nut prior to attempting jam nut removal. Make sure to replace allen screw to prevent torque loss. Never use hammer and chisel to remove axle nuts.

### WARNING

Failure to back off the inner adjusting nut could cause bearing and axle spindle overheating or damage, which could result in the wheel locking up or coming off during vehicle operation.

### WARNING

Failure to torque the outer lock nut properly could cause the wheel to come off during vehicle operation.



# WHEEL BEARINGS *continued*

## INSPECTION

Inspect the inner and outer wheel bearing cups, cones and rollers for excessive wear or damage.

Refer to bearing and axle manufacturer's manuals for inspection and replacement requirements.

## LUBRICATION

For maximum bearing life, inspect wheel bearings and lubricant periodically, change lubricant regularly, and clean the hub assembly properly.

If you do not clean the hub assembly properly both originally and in subsequent service, you must adhere to a shorter lube change schedule. When adding oil or checking oil level, be certain to clean the cap and plug before disassembling, to help keep out dirt and road grime.

When you clean and dry parts or bearings for later use, pack and coat them with wheel bearing lubricant and wrap in clean waxed paper to prevent surface corrosion that might cause premature bearing failure.

1. Remove wheel hub and bearing cones. Clean all old grease or oil from wheel hub, bearing cones, and hub cap with kerosene or diesel fuel oil and a stiff fiber (not steel) brush.
2. Allow the cleaned parts to dry, or dry them with a clean absorbent cloth or paper. Grease and oil will not adhere to and protect a surface wet with solvent. The solvent may dilute the lubricant. Clean and dry your hands and all tools.

### DANGER

**DO NOT USE GASOLINE.** Also, do not clean these parts in a hot solution tank or with water and alkaline solutions such as sodium hydroxide, orthosilicates or phosphates.

3. Inspect oil seals, oil seal wiping surfaces, bearings, and bearing cups for indications of wear or damage. Replace any worn or damaged parts. Handle the bearing carefully during inspection (and packing, if grease is used) so the cage will not be bent or the rollers and cone damaged.

## GREASE-LUBRICATED WHEEL BEARING

Depending on operating conditions, speed, and loads, change lubricants whenever you replace seals, when you reline brakes, or every 100,000 miles (or Spring and Fall if yearly mileage is less).

At rebuild time, before you install wheel bearings onto spindle, coat bearing journals (to deter fretting corrosion) with a film of Lithium, 12-Hydroxy stearate grease or its equivalent.

## RECOMMENDED WHEEL BEARING GREASE SPECIFICATIONS

- Soap Type – Lithium, 12-Hydroxy stearate or equivalent.
- Consistency – NLGI No. 2 or NLGI No. 1
- Corrosion and Oxidation Inhibitors
- Base Oil – Solvent Refined Petroleum Oil
- Base Oil Viscosity at 210° F . . . . . 75 SUS (Minimum)
- Pour Point . . . . . + 10° F. (Maximum)

When you service grease-lubricated wheel bearings:

1. Pack bearing with pressure packer, if possible. If not, pack by hand, forcing the grease into the cavi-ties between the rollers and cage from the large end of the cone.
2. Pack the hub between the two bearing cups with grease to the level of the smallest diameter of the cup.
3. Assemble the hub and bearings on the axle, being careful not to damage the oil seals or bearing. Adjust the bearings.

## OIL-LUBRICATED WHEEL BEARING

Check oil-lubricated wheel bearings every 1,000 miles.

Change oil when you replace seals, when you reline brakes, or at least once a year. Use a gear-type oil: SAE 140 if temperature is above freezing, SAE 90 if temperature is below freezing, or a multipurpose oil with an SAE range of 85 to 140 for year-round conditions.

## SERVICE

When you service oil-lubricated wheel bearings:

1. Wipe a film of oil on the bearing spindle to prevent rust behind the inner bearing cone.
2. Assemble the hub and bearings on the axle, being careful not damage the oil seals or bearings. Adjust the bearings.
3. Fill hub with oil to level indicated on cap, as shown in the illustration on the opposite page (pg. 13).

**NOTICE:** Always clean cap and plug before reassembly.

4. Rotate wheel and recheck lubrication level.

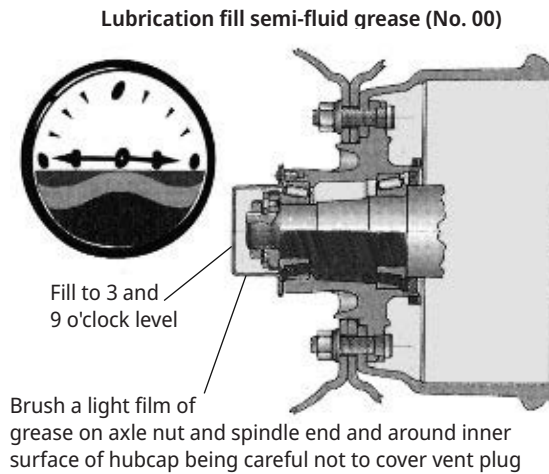
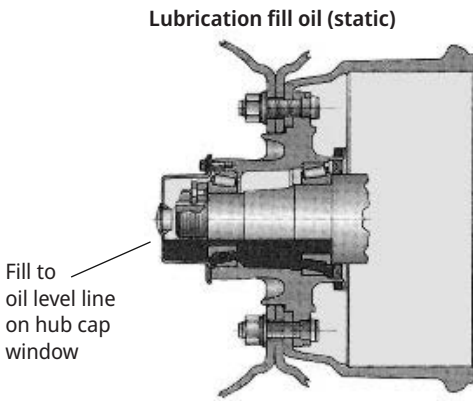

## SUSPENSIONS

### **⚠ WARNING**

**Broken spring leaves, missing or loose U-bolts, or other defective conditions likely to cause axle shift are hazardous.**

**Check** wear pads in hangers. If they are wearing thin, install new pads or the spring will cause permanent damage to the hanger. Do not operate with broken spring leaves.

**Check** to see if all springs can make proper contact with wear pads. Twisted springs and cocked hangers can cause uneven spring contact with wear pads and will result in excessive wear on the suspension.

**Check** to see if there is sufficient clearance between the springs and the sides of the hangers and rockers. Improper spring centers or hanger spacing can create binding in this area, resulting in excessive wear.

**Check** the equalizer to see that there are no obstructions to movement during operations. If equalizer movement is restricted by an obstruction, the axle "walk" will not be sufficient, and damage will result. Check the rocker beam to see if there is adequate clearance between the ends of the spring and the rocker beam hub when the axle is both loaded and unloaded.

**Check** welds to see that no cracking has occurred between the spring seats and axles, and between the hangers and sub-frame.

Threaded fasteners should be checked for proper tightness after an initial break-in period of 3,000 to 5,000 miles. Torque should be rechecked every 25,000 miles.

The replacement of worn bushings is considered normal preventative maintenance. Bushings showing signs of wear should be replaced before they damage the parts they are pressed into. Routine torque maintenance will prolong the life of bushings.

### **AIR-SPRING SUSPENSION**

The air-spring suspension height is controlled by height control valves that maintain a constant trailer height by pressurizing or exhausting air in the air springs as needed to support the load being carried.

You must build up to and maintain your trailer's air pressure at more than 70 psi for van trailers and 80 psi for platform trailers before operating the trailer. The air protection valve will not operate until you have 70 psi on van trailers and 80 psi on platform trailers in the system. This valve automatically maintains a safe air brake pressure higher than 70 psi for van trailers and 80 psi for platform trailers in the event of an air loss due to a failure in the suspension system.

If an air-spring failure occurs on one side, it is recommended to completely deflate the suspension and temporarily operate on the air springs' internal rubber bumpers to allow your trailer to be moved to a shop for repairs.

To deflate or cut off the air pressure to the damaged air spring, disconnect the height control valve actuating levers from their link assemblies and rotate to the vertical down position.

**Check** air lines and fittings for leaks.

**Check** air springs and proper clearance when inflated – minimum clearance is 1 3/4".

**Check** axle clamp group to be sure that all bolted connections are properly torqued. For proper torque requirement refer to the suspension manufacturer's maintenance manual. Worn component parts or loose U-bolts can allow the vehicle to roll or sway.

Excessive play in the beam pivot connection area can cause premature tire wear and erratic handling characteristics. Loose bolts at this connection will cause the rubber bushings to wear out prematurely.

## SUSPENSIONS *continued*

The shock absorbers should be replaced at the first sign of leaking hydraulic fluid. Worn shocks will allow tire hop and yield poor handling characteristics.

Many air suspensions are equipped with air control kits. The air control kit allows the raising or lowering of the vehicle bed by inflating or exhausting air from the air suspension. Do NOT operate the vehicle when the suspension is in the lowered or raised position.

Improperly maintained air suspensions will result in trailer suspension damage which includes bushing wear and irregular tire wear.

By customer specification, Great Dane may have installed any of the following air-spring suspensions on your new trailers.

Neway or SAF Holland models  
Reyco models  
Hendrickson models  
Meritor models  
Tuthill models

Please reference the bibliography in the back of the manual to obtain address for ordering manufacturer-specific maintenance manuals.

### LEAF-SPRING SUSPENSION

Check the torque of all suspension bolts after initial break-in period on the road and thereafter at regular intervals not to exceed 25,000 miles. Follow the torquing recommendations of the suspension manufacturer. If they are not available, use the following table of torque recommendations for clean dry threads. The use of lubricants will apply more tensile force for the same torque. If lubricants are used, decrease torque approximately 30%.

1"	14 UNC	350-375 lb-ft
7/8"	14 UNF	275-300 lb-ft
5/8"	18 UNF	75-90 lb-ft
5/8"	18 UNF	125-155 lb-ft (step bolts)
1/2"		40-50 lb-ft

It is especially important to maintain torque on U-bolts, equalizer bolts, and torque arm bolts. Torque the nut side of torque arm bolts only. Torquing the bolt heads will not produce the desired clamping force.

**NOTICE:** Loose U-bolts can result in spring damage.  
Improperly torqued bushing bolts can produce premature bushing wear.

## RUNNING GEAR ASSEMBLY

Inspection of upper running gear rail weld attachment to the trailer for weld fatigue cracks is a requirement of the annual FMCSA inspection. All trailer structures should be inspected for weld fatigue cracks and/or loose fasteners and any found should be corrected as a part of routine PM (preventative maintenance) serv-ice. Any defects in a trailer should be corrected to the manufacturer specifications before the trailer is returned to service.

### FIXED SUSPENSION

1. If the trailer is equipped with a fixed suspension, visually check all bolts connecting the suspension frame assembly to the upper running gear rails.
2. If these bolts need replacing, use only Grade 5 (minimum) bolts with Grade B (minimum) locking-type nuts. Be careful in selecting the proper bolt grip length so that threads are not at the interface of the rail/frame joint.

### SERVICING RIMS & WHEELS

For information on servicing wheels and rims, refer to OSHA 29 CFR 1910.177 and to the appropriate wheel and rim manufacturer's manuals. Also refer to *Servicing Single-Piece and Multi-Piece Rim Wheels*, U.S. Department of Labor pamphlet, OSHA 3086 and the accompanying two chart set, available from OSHA regional offices.

### WARNING

Tire and wheel/rim servicing can be extremely dangerous and must be done only by trained personnel using proper tools and procedures. Information about tire and wheel servicing can be obtained from:

US Department of Labor  
OSHA Publications Office  
200 Constitution Ave, NW  
Room Number N3626  
Washington, DC 20210  
Telephone: 800-321-6742

NHTSA  
Auto Safety Hotline  
1200 New Jersey Avenue, SE  
Washington, DC 20590  
Telephone: 800-424-99153

[www.safercar.gov](http://www.safercar.gov)

### DANGER

Tires must only be inflated while in a restraining device/safety cage.

## SINGLE-PIECE RIM WHEELS

Illustrated, complete safe operating procedures are provided on the wall chart "Mounting and Demounting Procedures for Truck/Bus Tires" available from the Department of Transportation, and OSHA.

The following minimum steps are recommended to provide maximum safety when servicing single-piece wheels:

- The tire must be completely deflated by the removal of the valve core before demounting.
- Mounting and demounting of the tire must be performed only from the narrow ledge side of the wheel. Care must be taken to avoid damaging the tire beads, and the tire must be mounted only on a compatible wheel of mating bead diameter and width. Proper tools must be used.
- A non-flammable bead lubricant must be applied to bead and wheel mating surfaces before assembling, unless the wheel manufacturer recommends against the use of any lubricant.

- If a tire changing machine is used, the tire may be inflated only to the minimum pressure necessary to force the tire bead onto the rim ledge and create an airtight seal before removal from the tire changing machine.
- If a bead expander is used, it must be removed before the valve core is installed and as soon as the rim wheel becomes airtight (when the tire bead slips onto the bead seat).
- The tire must always be inflated within a restraining device/safety cage.
- The tire must not be inflated to more than the cold-inflation pressure molded in the sidewall unless a higher pressure is recommended by the manufacturer.
- Cracked, broken, bent, or otherwise damaged wheels must not be reworked, welded, braced, or otherwise heated.

# RIM AND WHEEL INSPECTION AND MAINTENANCE

1. Check all metal surfaces thoroughly, including area between duals and on inboard side of wheel. Watch for:
  - a. Excessive rust or corrosion buildup
  - b. Cracks in metal
  - c. Bent flanges, resulting from road obstructions
  - d. Deep rim tool marks on rings or in gutter areas
  - e. Loose, missing or damaged nuts or clamps
  - f. Bent or stripped studs
  - g. Damaged or missing rim drive plates
  - h. Mismatched rim parts
2. Remove damaged rims or wheels.

3. Mark damaged or hazardous areas so that part will be removed from service.

### WARNING

Excessively corroded or cracked rims or rings can be dangerous. Deflate tires prior to the removal of rims or wheels from vehicle.

4. Replace damaged parts. Insure that replacements are made with the proper sizes and types of rim wheels.

### DANGER

Be sure that replacements are made with the proper sizes and types of rim wheels.

5. Inflate tires only to recommended air pressures.

# RIM/WHEEL PROBLEMS



## RIM BASE CRACKS

**Circumferential crack at back flange radius or bead set.**

**Causes:** Overload and/or over inflation, damage due to tire tools, tire bead deep pitting or corrosion.

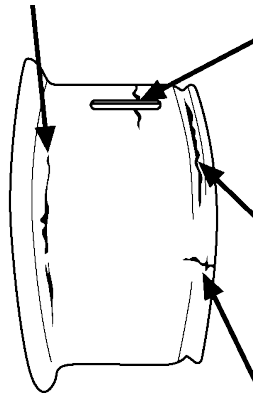

**Circumferential cracks in middle of rim.**

**Causes:** Damage at valve slot or elsewhere. Disc weld problem.

**Cracks in rim gutter.**

**Causes:** Over inflation, hammer damage, or improper cleaning. Butt weld projection.

**Crack across mounting bevel in a demountable rim.**

**Causes:** Excessive clamping torque or improper components.

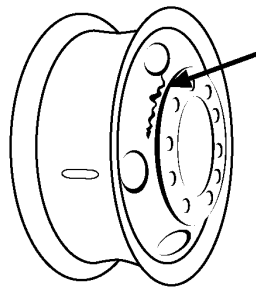

## DISC FAILURES

**Cracks at disc nave and/or handhole.**

**Causes:** Bad fit-up, damaged hub, or overload. Sharp edge at handhole.

## TUBELESS RIM LEAKS

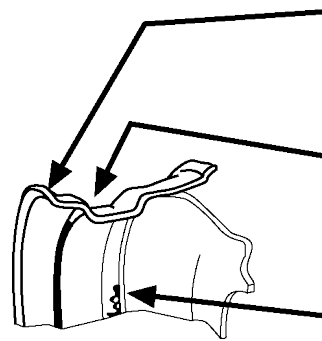

**Circumferential crack at bead set.**  
Caused by pitting and erosion by the tire bead.

**Circumferential crack in well radius.**  
Caused by overload and over inflation.

**Circumferential crack at attachment weld.**  
Caused by overload and over inflation.

**NOTE:** Wheels with well-welded discs may not be approved for use with radial tires.

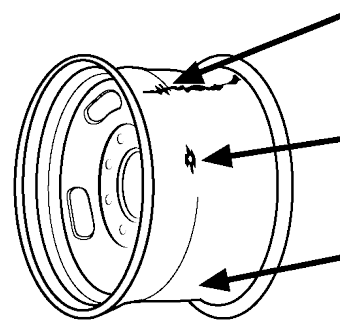

**Leak at butt weld.**  
Caused by cracked or damaged weld.

**Leak at valve hole.**  
Caused by damage or severe corrosion.

**Leak under tire bead, groove or ridge across bead seat.**  
Caused by corrosion, tire tool marks, bent flange or other damage.

## TIRE CHANGES

1. Check all metal surfaces as listed in the section Rim and Wheel Inspection and Maintenance. A more thorough check may be made, however, after the tire has been demounted. Watch particularly for the damages shown in this section, and refer to recommendations if corrective measures are required.

## **⚠ DANGER**

Be sure that replacements are made with the proper sizes and types of rims and rings.

**NOTE:** Openings between ends of split side rings must not be less than 3/32" except where the ring design calls for an abutting condition, or more than 5/16" after ring is seated in during operation. Split lock rings used with endless side rings must not butt.



### STUD HOLE CRACKS

Hub or outboard drum may be damaged or broken.  
Must provide flat backup.

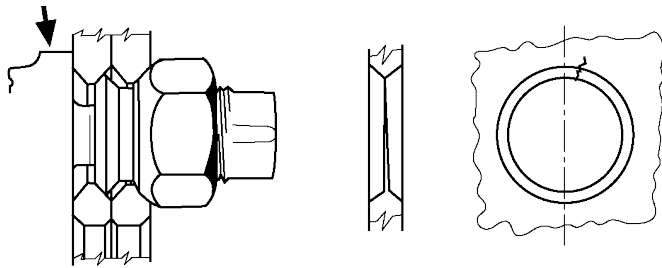

Double-capnut wheel mounting preload is force applied to the disc by torquing nuts. Inner cap nut must be tightened before tightening outer nut.

**Crack originating from thin edge of bolt hole.**

**Cause:** Damaged or worn out chamfers.

This surface should be convex, not concave.

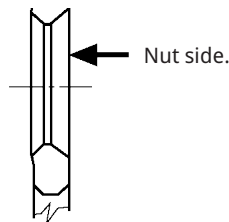
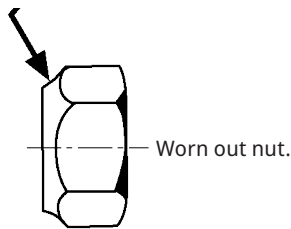

**Chamfer extruded on side opposite nut.**

**Cause:** Damaged or worn out chamfers.

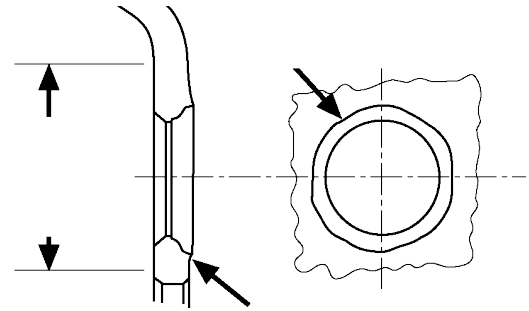

**Cause:** Loose cap nuts or insufficient preload due to damaged threads or improper torquing or by worn out nuts.

### WHEEL CRACKS

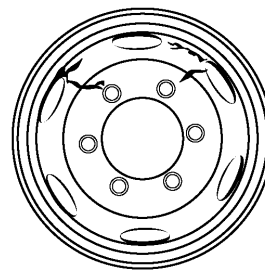

**Handhole to handhole.  
Handhole to studhole.  
Handhole to rim.**

**Causes:** Overloading.

**Studhole to studhole.**

**Causes:** Loose cap nuts.  
(Also see chamber problems).

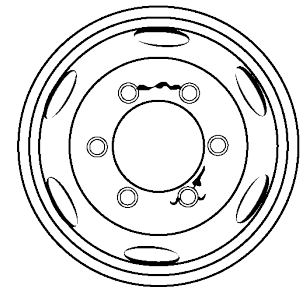

## TIRE CARE

### PROPER INFLATION

**⚠ DANGER**

**Always inflate tires in a safety cage.**

Inspect trailer tires thoroughly and often, paying special attention to inflation. Always use a reliable tire pressure gauge. Always check when the tire is cool, inflating to the recommended pressure for the maximum load to be carried but not exceeding the pressure limit molded into the tire and the rim or wheel rating. Always use valve stem caps to keep a tight air seal and keep out dirt and moisture.

Even with proper inflation, radial tires tend to show a sidewall bulge normally associated with under inflation.

After mounting a new tire, recheck inflation pressure after 48 hours.

Inflation pressure increases during normal operation as tire temperature increases, often as much as 10 to 15 psi. Higher pressure may be a sign of overloading, under inflation, excessive speed, improper tire size, or a combination of these factors. Determine the cause of any abnormal air pressure increase and correct it.

**UNDER INFLATION** is a tire's greatest enemy. Check tires with an accurate gauge before each trip and at least once a week.

## TIRE CARE *continued*

Running a tire under inflated can have serious consequences in addition to reducing tread life. Heat buildup can cause the tire body to deteriorate, resulting in separation of the tread from the body or belt ply. A soft tire overdeflects, causing fatigue breaks in the body cords. Continued overdeflection causes breaks in the body cord construction, leading to sudden air loss.

**Running duals with one tire flat or severely under inflated will lead to intense heat buildup in the flat or low tire due to external and internal friction – to the extent that the casing will likely burst into flames.** Also, one tire of a dual running flat or low means the other is overloaded and may fail.

**OVER INFLATION** can also cause serious damage to a tire. Because a tire is more rigid when over inflated, it does not absorb road shocks as well. This can lead to body breaks when impacting a bump or chuckhole. It can stress the rim, leading to rim failure. And over inflated tires are more likely to cut, snag, and puncture.

**NOTICE:** Over inflation cannot increase the carrying capacity of a tire above its maximum rated load.

### DANGER

Tires operated in a flat condition may catch fire resulting in potential product and property loss.

#### PROPER MATCHING AND SPACING OF DUALS

Mismatched dual tires force the larger diameter tire to an overload condition, causing it to overdeflect and overheat. The smaller diameter tire will lack complete road contact and will wear faster and more irregularly. Tread or ply separation, tire body breaks, and blowouts can develop from mismatching duals.

Permissible diameter differences between a tire and its dual mate having equal inflation pressure are:

- 1/4" for 8.25 cross section (tubeless 9-22.5) and smaller sizes
- 1/2" for 9.00 cross section (tubeless 10-22.5) and larger sizes

To determine the difference in diameter measure the tires forty-eight hours after initial inflation with a steel tape. Measurements on the trailer can be made by string gauge, straight edge, tire caliper, or a large square.

Proper spacing between duals is necessary to prevent sidewall contact at the "six o'clock" position. Such contact creates excessive heat which can destroy the tires.

#### TIRE BRANDING

Whenever possible, tire branding should be in the branding panel on the sidewall of most truck tires. Use extreme caution to prevent branding too deeply. The ideal branding depth is 1/32", and in no case should it exceed 1/16".

If no branding panel is on the tire, brand the sidewall midway between the rim flange and the tire's maximum section width.

**NOTICE:** Never brand in the critical sidewall flexing area near the tire maximum section width of a radial ply tire. Branding that is too deep or in the wrong place on the tire can result in tire failure. Consult the tire manufacturer for more detailed instructions.

#### MIXING RADIAL AND BIAS-PLY TIRES

Radial tires and bias-ply tires differ considerably in their cornering force characteristics and spring rates. The best overall performance usually can be achieved by using tires of the same size and construction on all wheels. However, different types of tires can be used in combination on tandem axle trailers and multiple-axle trailers under certain conditions.

Never mix different tire sizes or tire construction on the same axle. Bias or radial tires may be used on either axle of two-axle trailers if the trailer has dual rear wheels or is equipped with wide-base single tires.

#### TUBE AND FLAPS FOR TUBE-TYPE RADIAL TIRES

Since the tube holds the air, the importance of the tube in the satisfactory performance of the tire is obvious. The flexing characteristics of a radial truck tire require a special inner tube. Never use a tube that has not been identified as being suitable for use with radial-ply tires.

Both tubes and tires must be the same size. For example, a 10.00R20 tube must be used with a 10.00R20 tire, and the tube must be for a radial tire.

When using flaps, use radial flaps. Radial flaps are manufactured especially for radial truck tires. For correct flap size, check the tire manufacturer's specifications. Always check for the correct designation before installing a flap in a radial truck tire.

**Note:** Always use new radial tubes and flaps when mounting new tube-type radial tires.

Replace any tire that has fabric exposed through the tread or sidewall, or that has less than 2/32" tread depth.

## TIRE LOADS

Great Dane Trailers, as required by the safety regulations of the National Highway Traffic Safety Administration, has assigned a Gross Axle Weight Rating (GAWR) for each axle on the undercarriage. (See example certification plate at right)

The GAWR and tire information shown on the vehicle certification plate was applicable at the time the trailer was manufactured. If the tires or other components of the running gear have been changed or altered since the trailer was manufactured, the GAWR may have changed. This should be checked with Great Dane Trailers Customer Service Department.



# AXLE ALIGNMENT

## TIRE LOADS

Improper axle alignment with the trailer frame will cause excessive tire wear and trailer "dogtracking". In extreme cases, depending on trailer length, the outer tire of the curbside wheels may have little or no contact with the road, causing the entire wheel load to be carried by the inner tire. Also, trailers that "dogtrack" will not have identical right and left turning characteristics, which complicates driving in areas with narrow streets and sharp turns. Even though Great Dane aligns every trailer's axles prior to delivery, we still recommend that axle alignment be checked and corrected if needed on initial in-service and again every 20,000 miles.

When aligning axles, suspension should be in a natural, relaxed state, free of any "binds" before taking measurements. To achieve this relaxed condition, make sure the vehicle is unloaded. Then roll it back and forth on a level floor. Avoid brake application including parking brakes. Vehicle must be level from side to side as well as from front to rear.

To inspect the axle alignment, measure the distance from the kingpin to the trailer axle on each side (and from axle to axle for tandem-axles) as specified below. But first fabricate a rigid S-hook that can be hooked over the kingpin and attach a steel tape to it.

## SINGLE-AXLE PROCEDURE

1. Remove any parts of the undercarriage that will interfere with the tape when it is stretched between the kingpin and the ends of the axle – or avoid removing the parts by using a Sweenypogo stick or equivalent device. Remove outer wheel if disc type, or tire and rim assembly if steel spoked, or entire assembly – depending on the wheel equipment on the trailer.
2. Level trailer to its normal road condition.
3. With the S-hook and steel tape, measure the distance from the kingpin to the center of the end of the axle on each side (measurements A and B on the single-axle illustration). These measurements must be within 1/8" of each other.

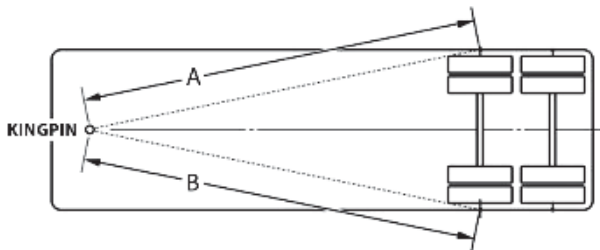

## TANDEM-AXLES PROCEDURE

1. With the tandem axles in their natural working position, roll the trailer back and forth over a level surface a few times to permit the connecting linkage to position itself properly and center front and rear wheel track.
2. Remove any parts of the undercarriage that will interfere with the tape when it is stretched between the kingpin and the ends of the front axle – or avoid removing the parts by using a Sweenypogo stick or equivalent device. Remove outer wheel of this axle if disc type, or tire and rim assembly if steel spoked, or entire assembly – depending on the wheel equipment on the trailer.
3. Level trailer to its normal road condition.
4. With the S-hook and steel tape, measure the distance from the kingpin to the center of the end of the front axle on each side (measurements A and B of the tandem-axles illustration). These measurements must be within 1/8" of each other.

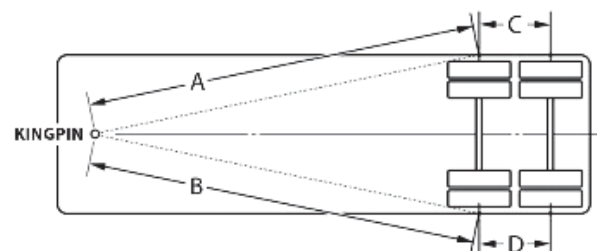

## TIRE CARE *continued*

5. Measure the distance, on each side, from the center of the end of the front axle to the center of the end of the rear axle (measurements C and D of the tandem-axles illustration). These measurements must be within 1/16" of each other. (Illustrated is a gauge that simplifies this measurement.) It can be made of drill rod or pipe fittings. The materials and details are less important than that the resulting gauge be rigid and true. (The pointer arms of the gauge should be parallel and in the same plane.)

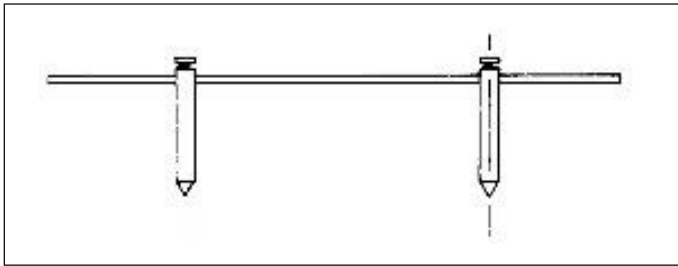

### CORRECTING MISALIGNMENT

If any of the related measurements are not within stated dimensions, inspect the trailer suspension thoroughly for loose, worn, or broken connecting and supporting parts. Replace worn or broken parts. Then adjust the suspension to bring the axle or axles into alignment.

When there is a slight amount of irreducible misalignment in one axle assembly of a tandem-axles trailer, the other can sometimes be moved a corresponding amount in the opposite direction to reduce the tendency of the trailer to “dogtrack”, but it should not be moved more than 1/16" from its optimum alignment position.

This method of correcting misalignment is not recommended as a permanent and sound solution – there is no substitute for correctly installed and aligned axles. The limits of 1/8" appear very small compared with the overall dimensions of the trailer, but they are recognized as the maximum permissible limits of misalignment. Also, the relatively small size of these limits makes it important that the measurements be accurate.

### TOE-IN AND TOE-OUT

Toe-in and toe-out can be checked accurately with front axle aligning equipment designed for automotive service.

### AXLE CAMBER

Axle camber should be measured accurately on an alignment machine made for the purpose. It is often advisable to consult a qualified specialist with the equipment both to measure and to correct errors of camber. NOTE: Most trailer axles have no camber.

## UPPER COUPLER AND KINGPIN

Inspect the kingpin and the upper coupler on the trailer at regular intervals to be sure that they have not suffered damage or undue wear. Although the kingpin is made of hardened forged steel, it is still subject to wear and can be chipped or broken with abuse. Always check the bottom locking flange of the kingpin to determine its condition. The upper coupler fasteners should be inspected to see that they are in place and properly tightened.

Before coupling the trailer to its tractor be certain that the tractor fifth wheel is properly lubricated and the fifth wheel jaws are open to receive the kingpin.

If the bottom rail attachment fasteners of a van upper coupler are damaged they should be replaced with fasteners of the same design and strength. Loose or missing fasteners must be replaced. Great Dane should be contacted for replacement information. If this information is not available, Grade 5 (minimum) bolts and Grade B (minimum) locking type nuts may be used but must be torqued properly.

Be careful in selecting the proper bolt grip length so that threads are not at the interface of the coupler/rail joint. It is recommended that, if possible, the next larger diameter fastener should be used to provide a good tight fit. If this is not practical, then replace the fastener with

the same size as removed. Drill a companion hole of the same diameter with proper spacing between the holes and add an additional fastener. This method assures adequate fasteners to contain the upper coupler loads.

BOLT TORQUE REQUIREMENTS		
CLEAN DRY THREADS LB-FT		
BOLT SIZE	GRADE 5	GRADE 8
3/8" UNC	30	45
3/8" UNF	35	50
1/2" UNC	75	110
1/2" UNF	90	120
5/8" UNC	150	220
5/8" UNF	180	240
1" UNC	580	900
1" UNF	640	1000

# PINTLE HOOK

1. Clean and check for proper operation. This should be done at each TPM.
2. Inspect for worn, damaged or missing parts. Replace only with compatible replacement components.
3. Regularly lubricate the latch and lock pivots with a light-oil lubricant. On models equipped with a grease fitting, apply a small quantity of grease through the grease zerker fitting.
4. Check mounting bolts for proper torque. For 3/4" bolts with dry threads use 275-325 lb-ft for grade 5 bolts and 400-450 lb-ft for grade 8 bolts.
5. Check air plunger adjustment. Refer to the recommendations of the pintle hook manufacturer.
6. The structural mounting assembly must be inspected at each TPM to insure against fatigue problems.

# SUPPORT GEAR

The support gear and brace system is designed to support a fully loaded trailer at its rated GVWR when parked on a solid level surface. The brace system and the mounting bolts should be maintained as manufactured to provide a safe operating condition. Damaged components must be replaced before the vehicle is reloaded. SUPPORT

## GEAR LUBRICATION

1. Lubrication quantity and recommended intervals vary according to the conditions in which the support gears are operated. It is good preventive maintenance to lubricate the support gear one time during the first six months of use and every twelve months thereafter.
2. In severe cold-temperature operations, many fleets completely fill the top head and gear box with a high-quality, low-temperature lubricant.



# REAR IMPACT GUARD

## MAINTENANCE AND REPAIR

Federal Motor Carrier Safety Regulations for rear impact guards require the proper maintenance and repair of trailer guards. Trailer guards are subjected to impacts and stress in docking and loading operations. These impacts, as well as the stresses applied by the use of dock restraint equipment, if excessive, can damage any rear guard. A damaged guard may not satisfy the performance requirements now mandated by NHTSA and FMCSA, and may not be as strong as originally designed and manufactured by Great Dane. Great Dane cannot be responsible for a guard that has been damaged, or for one that is not repaired in accordance with Great Dane's design and manufacturing specifications.

Rear impact guards clearly now have attained the status of safety equipment and are as important as lighting and reflector systems or braking systems, which are also regulated by NHTSA, FMCSA and most state departments of transportation. Pre-trip inspections have for years included the DOT bumper. Now the integrity of rear impact guards must be maintained to meet NHTSA standards. Broken welds, bent components, missing or loose fasteners, excessive corrosion or other damage to any trailer guard will likely affect its performance in the event of a rear-end collision. For these reasons, detailed guard

inspection, service and repair records should be maintained on all guards for your protection. Repairs must be made in accordance with the guard's original design specifications. Any question regarding the repair of a Great Dane guard should be directed to one of Great Dane's Distributors or Branch Parts and Service facilities, which are available to discuss any proposed repair with its customers. Where possible, Great Dane recommends that all guard repairs be made at one of Great Dane's service facilities.

## PRESERVATION OF EVIDENCE

In the unfortunate event that a Great Dane trailer is impacted by another vehicle in a rear-end collision, it is essential for the protection of both you and Great Dane that the condition of the guard and its attachments be documented immediately. If possible, photographs should be taken before the vehicles are separated. Photographs should also be taken after separation, including photographs showing the trailer understructure and all guard attachment components. These photographs should be taken before any repair is made. Moreover, any guard components that are removed as part of a repair should be labeled and saved until all claims arising out of the accident have been resolved. If you have any questions about these instructions, please contact Great Dane's Customer Service Department.



# SIDE AND ROOF PANELS — VANS

Side and roof panels are critical structural members of the trailer. Small holes can be patched using an overlay panel with blind rivets. Large holes may require panel replacements. When repairing large holes or when replacing full panels, use solid rivets of 2117-T4 aluminum for aluminum panels, or solid rivets of type 302HQ for stainless steel panels.

## FIBERGLASS-REINFORCED PLYWOOD (FRP)

FRP panels are of a composite construction where plywood is overlaid with fiberglass cloth, resins and gelcoats. It's very important that any cuts or scrapes through the outer glass coatings be repaired immediately to protect against water intrusion into the plywood core. If the plywood core is exposed to moisture for any period of time, delamination and/or rot may occur.

FRP panel connections to rails, front, and rear frame connections are sealed with a high-grade sealer at the time of manufacture. As with any coating or sealer, this sealer may deteriorate due to age and

weathering and should be inspected and resealed as necessary after 24 months in service.

A Great Dane FRP repair manual is available upon request.

## BONDED ROOF

Your equipment should be directed to your qualified Great Dane branch or dealer repair shop for proper repairs. If this is not possible, you should contact Great Dane for proper repair instructions and information on necessary bonding materials.

### WARNING

**No attempt should be made to repair a bond-in-placeroof bow/roof sheet assembly without a complete understanding of the design, materials and the equipment needed to achieve the proper repair.**

# REAR FRAME, DOORS AND HARDWARE

## REAR FRAME

The rear frame should be inspected at regular intervals for damage to the frame, doors and hardware from impacts with loading docks, abutments or other devices in the loading area. An area of particular concern is damage to the rear posts at hinge butts. This can cause binding, door distortion, and eventual failure to the door, door hinges, or both.

## DOORS

Check rear doors for damage or warpage to panels, frame or hinges. Compression seals should be checked to see if the seals need to be repaired or replaced to ensure a tight closure. The seals around vent doors should be checked and maintenance performed as needed. Interior linings or insulated doors should be checked for damage or loose or missing fasteners and repaired as required. Safety equipment in the rear frame area (such as door hold backs, grab handles, steps, ramps and slip-resistant materials) should be inspected at TPM. If necessary, they should be repaired or replaced.

## HARDWARE

1. Check anti-rack rear door locks for damaged, distorted, or cracked tubes resulting from impacts.
2. Check operation and engagement of cams into keepers.
3. Inspect bearing plates for loose or missing fasteners.
4. Check tamperproof fasteners in gravity keepers and the top and bottom hinge.
5. Check the operation and engagement of the third-point lock (on some models).
6. On insulated trailers, inspect the interior sealing surfaces (PVC wedging) to be sure that the thermal efficiency is maintained. Repair or replace any components as needed.

## OVERHEAD DOORS

If the door becomes difficult or impossible to operate, have it repaired or adjusted by a qualified mechanic.

1. The door spring is constantly under extreme tension. Repairs and adjustments, especially to the door counterbalance assembly, are potentially dangerous and must be performed by qualified service personnel only.
2. Clear any obstruction from the door tracks and the base of the mounting angle where the door comes down to the floor.
3. Perform regular inspection and maintenance on the following items:
  - a. Be certain that all nuts and bolts are tight and secure.
  - b. Check cables full length and at attachment points and replace all frayed or otherwise damaged cable.
  - c. Check cable drums for tightness against bearings.
  - d. Check all rollers for smoothness of operations and have all sliding or otherwise damaged rollers replaced.
  - e. Replace frayed, damaged or severely worn pull straps.
  - f. Check the door lock to be sure that it is free, and fully operational.
  - g. Replace broken or damaged hinges.
  - h. Periodically use a light lubricant (not grease) on rollers, counterbalance hinges, and lock, as necessary, to maintain a smooth door operation.

# ENTRY AND EXIT

Regardless of who may have manufactured or installed the access equipment, it has been installed for the safe entry and exit of persons and/or products. It is necessary that these items be included in your regular Trailer Preventive Maintenance (TPM) Program. These items must be checked for proper safety operations. Welds and fastener

connections must be checked and corrected as necessary. Latches, hold downs, etc. must be checked and must function correctly. These items must be kept clean and free of materials that may cause them to become slippery. These items must be cleaned and degreased as necessary for a safe operation.

## FLOOR SYSTEM

The floor system should be inspected regularly so that the fail-safe rating that was manufactured into the floor system can be maintained.

### WARNING

Trailer floors can become slippery. Be careful when walking in or on the trailer. When floors become slippery, they should be properly cleaned and degreased, rather than using salt or other chemicals to increase traction.

### TOP FLOOR

Check the top floor for loose or missing screws, separated lamination or failing floor boards, deformed crossmembers, rear impact area damage from forklift traffic, weld separation, or fatigue cracks in aluminum floors.

Undercoating on wood floors should be checked periodically and re-undercoated if necessary. (Every 24 months.)

### CROSSMEMBERS

Deformed, twisted, or damaged crossmembers should be removed and replaced with original equipment. End-clip crossmember connections to bottom side rails should be checked for loose, damaged or missing rivets and the general condition of connections.

**CAUTION:** Loose connections will cause premature failure of the floor system. Loose connections must be corrected as soon as they are found.

Great Dane should be contacted for fastener replacement information. If this information is not available, Grade 5 (minimum) bolts and Grade B (minimum) locking type nuts may be used but must be torqued properly.

## INSULATED TRAILER MAINTENANCE

Proper education and knowledge by the operators and maintenance personnel using refrigerated trailers can be beneficial in many ways: cleanliness, sanitation, maintenance of reefer exteriors and interiors, lining finishes, insulation efficiency, operation of doors, and mechanical refrigeration units. Safety and profitable operation are closely related, and they are dependent on the normal operation care and thoroughness of the maintenance.

### CLEANING

**Steam Method:** Live steam does a good job of cleaning and deodorizing. However, steam is harmful to wood liners, sealers, and exposed vapor barriers, and it is not recommended. If steam must be used, a waterproof sealer should be applied to both sides and all edges to protect the trailer.

**Detergents:** If detergents are used, they must be mild, and they must be properly rinsed after application. All joints should be resealed as required to maintain a watertight seal.

**CAUTION:** Insulated and refrigerated trailers are designed to transport food and food products. The vehicle must be clean before loading.

**DO NOT** transport products or use cleaning agents in these trailers that could cause contamination of any food product.

**Exteriors:** Cleaning the outside of refrigerated trailers should be done the same way dry-freight vans are cleaned. Live steam does a good job of cleaning and brightening the exterior surfaces of van trailers. Application of a protective transparent coating may be used to protect the exterior surface from further oxidation. Do not use brighteners or acids on the trailer.

Note: A trailer with open holes should not be steam cleaned until the holes have been patched or panels replaced. Allowing moisture or chemicals to enter the walls or roof through holes will cause corrosion and may add weight to the trailer.

## INSULATION TRAILER MAINTENANCE *continued*

### CHECK INSULATION EFFICIENCY

Weigh the trailer at regular intervals to determine if there is moisture accumulation or water pickup through condensation or leakage into the insulation. Check for spots where water may leak out during cleaning, other than from regular drain holes. This indicates water entrance into the insulation. The areas allowing water to enter must be located and properly sealed.

Keep a record of the length of time the mechanical refrigeration unit cycles and its frequency. An increase, of an appreciable degree,

in frequency and in duration of the cycles, or both, could indicate a general deterioration either in the trailer insulation or refrigeration unit.

Excessive air leakage may cause the refrigeration unit to run for long periods of time. Excessive air leakage indicates problems such as perforated walls or worn out areas of door seals or door locks around vents, side doors, and refrigeration units. These areas should be repaired.

## MAINTAINING INSULATION EFFICIENCY

### MOISTURE PICKUP THROUGH CONDENSATION

If it has been determined that you have moisture contamination in the insulation cavity, you should take one of the following steps:

- a. Open the doors of the trailer and park it in the sun. It takes several days of hot, sunny weather to equalize water vapors trapped in the trailer body with that of the outside air, or;
- b. Place the trailer in a controlled-heat, paint-drying oven to speed up the process of drying.

### RAIN WATER LEAKAGE

- a. Check outside and inside of trailer for holes and loose joint seams through which moisture may seep.
- b. Waterproof all openings immediately by patching and sealing, or both, especially after accidents in which body and roof skin may have been cut. Synthetic-rubber-base-type sealer should be used for closing all minor openings.

### EXCESSIVE CYCLING OF REFRIGERATION UNIT

If the unit is operating properly, the excessive cycling could be caused by:

- a. Air transfer through leaking door seals.
- b. Deterioration of insulation.
- c. Unusually hot surrounding temperature.
- d. Refrigeration unit improperly sized for the intended temperature for that cargo.

### SUBFLOORS

Since subfloors are enclosed on the top side and open at the bottom, they are subject to considerable road splash and corrosion. Where they have deteriorated they should be repaired or replaced.

### DOORS, VENTS, HATCHES

When seals are worn out they must be replaced. Check and correct, as required, the alignment of door hinges and locks.

## SAFETY MEASURES — URETHANE FOAM

### URETHANE FOAM FLAMMABILITY

Urethane foam has achieved an extensive history in a variety of applications, including insulation in refrigerated trailers, because the performance of urethane insulation has been superior to other materials.

One area of concern is the fire potential and flammability of urethane when exposed during repair of surrounding areas. Urethane foam is combustible like cork, wood or other organic materials. When urethane is exposed to the intense heat of welding, flame cutting or other hot work wherein a high-density heat source is used in repairing an insulated trailer, certain precautions must be observed. Urethane foam burns (including fire-retardant types) producing toxic smoke which may or may not be visible to personnel.

### PRECAUTIONARY MEASURES

Clean the work area. Never allow urethane scrap or other organic materials to be in the work area or around the trailer. Do not allow foam material to accumulate on the job site.

1. Under no circumstances shall a direct flame be allowed to contact urethane foam. Urethane foam must be mechanically cut away and totally removed from around the repair area by at least two feet or an obviously safe distance away to prevent any flame from coming in contact with the urethane materials.
2. All combustible materials below the workpiece must be removed to prevent ignition from hot sparks or slag.

3. Should ignition or combustion of the urethane become evident (flame, smoke, charring, odor, etc.), hot work must be stopped immediately. All flames must be extinguished and additional urethane materials must be removed from the workpiece and/or workplace before hot work is continued.
4. A fire watcher equipped with a 15-pound CO2 or dry-chemical extinguisher must be posted at the job site during all hot work operations, and must remain for at least 30 minutes after such operations have been completed.
5. All work involving heat, especially burning and welding, must be performed in a well-ventilated area.
6. Interrupt burning and welding occasionally to prevent a buildup of heat.
7. Workers shall know what to do in the event of an emergency. Prior to work being started, workers must be aware of how to contact fire and medical personnel should the need arise.
8. In the event a urethane fire is encountered, immediate steps shall be taken to avoid breathing the toxic fumes associated with such fires.

Personnel fighting the fire must be equipped with NIOSH-approved, self-contained breathing apparatus. Personnel not equipped with NIOSH-approved, self-contained breathing apparatus must leave the area immediately.

### **WARNING**

**This trailer is insulated with urethane foam which is an organic material.**

**The following precautions shall be observed:**

1. Urethane foam will burn when exposed to flame or extreme heat. Foam shall be shielded with a thermal barrier when welding or torch cutting in its vicinity. Fire extinguishing equipment should be readily available.
2. Fires involving urethane can be extinguished with water, carbon dioxide or dry chemicals. Personnel fighting the fire shall be equipped with NIOSH-approved, self-contained breathing apparatus.

## PLATFORM TRAILERS

### MAIN BEAMS

Platform trailers are constructed such that the main beams provide both the load-bearing and load-carrying capability. It is important that no welding, burning, drilling, etc. ever be done on these main beams, as the structural capability will likely be drastically affected. No such items as sliding-base winches should be added to these beams as they would tend to twist the beams, especially on wide-frame platforms. The ability of these beams to take loads would be impaired due to the twisting.

If modification of the beam is ever necessary, the factory should be consulted prior to doing the work.

### CROSSMEMBERS

Crossmembers are used not only to carry loads into the main beams but are also used to maintain the main beams in a vertical direction.

Any area where crossmembers have been removed for any reason may cause twisting of the main beams and could cause a structural failure.

### EXTENDABLE PLATFORMS

The extendable platforms have more inspection points due to their complexity. In addition to the main rails and crossmembers, the lock pins should be inspected for proper protrusion and wear. If the diameter of the lock pin has 1/4" or more of wear it should be replaced.

The lock-pin safety-lock mechanism should also be inspected for proper operation. The two sections ride on rollers that have fittings to allow them to be greased at regular intervals. One additional caution is to keep the caps on all air connectors when they are not in use. These caps are necessary to keep dirt out of the air system.

## CONVERTER DOLLY

The fifth wheel on the dolly should be maintained in accordance with the vendor's recommendations. The suspension should be maintained following the same recommended preventative maintenance practices as previously listed for trailers.

Maintenance of grease lubricants on the fifth-wheel race is critical in the operation of multi-unit equipment. Dry fifth-wheel tables will result in "sticking" of the coupler plates during operation which can result in a "whipping" action of the multi-unit equipment.

### **WARNING**

**All coupling and safety devices associated with multi-unit operation must be inspected prior to each coupling to insure safe operation.**

# RUNNING GEAR ASSEMBLY PLATFORM AND CURTAINSIDE TRAILERS

## MOVEABLE SUSPENSIONS

1. Always check the condition of the locking holes in the main beam. Holes that are badly worn or elongated will result in undue slack in the slider unit, causing excessive wear and suspension misalignment.
2. Always check to see that the hold-down brackets, denoted as (A) in the diagram at right, are in good repair and have not been damaged. Trailers should not be operated if any of these brackets are not in proper position.
3. Check the pin cage assembly bolts for tightness after each year of service. Re-torque to 380 lb-ft.

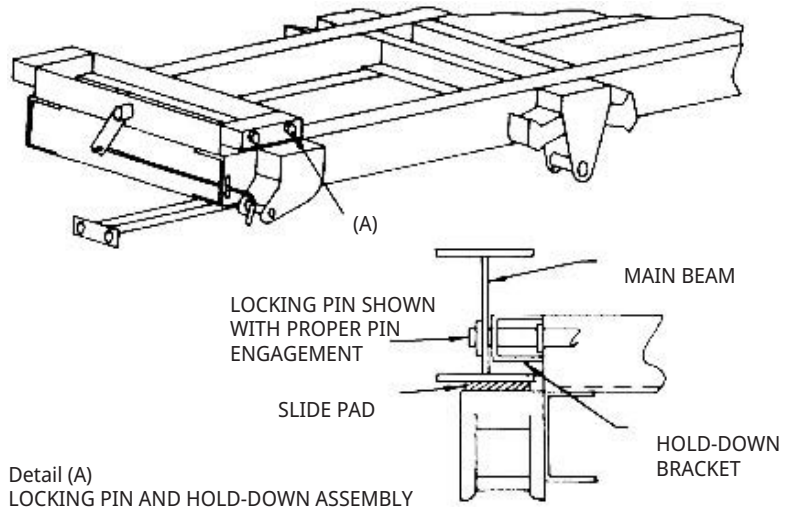

## FIXED SUSPENSIONS

1. If the trailer is equipped with a fixed suspension, visually inspect all connections at regular intervals to be sure there are no weld or fatigue cracks.
2. All cracks must be properly repaired and then re-welded.

# ALTERATIONS TO THE TRAILER

## MINOR ALTERATIONS

These should be made in accordance with good shop practices. Normally, minor alterations will not alter the rating shown on the trailer certification plate. A possible exception is the Gross Axle Weight Rating (GAWR).

The GAWR is the structural capability of the lowest-rated member of the running gear components, suspension and spring system, hubs, wheels and drums, rims, bearings, brakes, axles, or tires.

If components are substituted that are of equal or greater capacity than those used at the time of manufacture, then the GAWR need not be altered.

If components are substituted that have less capacity than those used at the time of manufacture, the GAWR on the certification plate must be lowered to a corresponding lower capacity.

## MAJOR ALTERATIONS

No major alteration of a Great Dane trailer should ever be made without first consulting the Great Dane factory. Major alterations can affect the structural integrity of the trailer, and can alter the GVWR and void the trailer's warranty coverage.

## FEDERAL MOTOR CARRIER SAFETY

There are many regulations that govern the use of and safe loading of motor vehicles. These are user requirements; therefore, they are your responsibility. If information regarding these requirements is not known to you or you need assistance, contact:

Federal Motor Carrier Safety Administration  
Department of Transportation  
1200 New Jersey Ave, SE  
Washington, D.C. 20590  
(855) 368-4200

or

the various states' departments of transportation.

## DURING EACH ANNUAL FMCSA VEHICLE INSPECTION

It's a requirement that all trailer structures be inspected for weld or fatigue cracks and/or loose fasteners and corrected to O.E.M. specifications before they are returned to service. Upper slide rail to crossmember attaching welds and pintle hook assembly welds must be included during inspection.



# GREAT DANE MAINTENANCE MANUAL BIBLIOGRAPHY

- Recommended Maintenance Practices Manual  
Technology and Maintenance Council (TMC)  
American Trucking Association  
2200 Mill Road  
Alexandria, Virginia 22314
- TTMA Technical Bulletins and Recommended Practices  
Truck Trailer Manufacturers Association  
1020 Princess Street  
Alexandria, VA 22314
- SAE Handbook  
Society of Automotive Engineers  
400 Commonwealth Drive  
Warrendale, PA 15096-0001
- Cast Beam Maintenance Manual XL-AR368-01  
Duralite Suspension Maintenance Manual XL-MS175-02  
NS190 Series Maintenance Manual XL-AR415-01  
NS400 Series Suspension/Slider Maintenance Manual XL-AR320-01  
Holland RL & AR Series Maintenance Manual XL-AR316-01  
Holland Binkley Landing Gear XL-LG330-01 Mark V Landing Gear Maintenance Manual XL-LG225-01  
The Holland Group  
P.O. Box 425  
Muskegon, Michigan 49443  
[www.thehollandgroupinc.com](http://www.thehollandgroupinc.com)
- How to Operate and Maintain Your Thermo King  
Thermo King Corporation 314  
West 90th Street Minneapolis,  
Minnesota 55420  
[www.thermoking.com](http://www.thermoking.com)
- Maintenance Manual No. 14 - Trailer Axles  
Maintenance Manual No. 14S - RHP 11 Trailer Air Suspension  
MM-99108 Air Actuated Disc Brakes  
MM-0420 Trailer Axles with Unitized Wheel Ends  
MM-0180 Enhanced Easy-Stop Trailer ABS with PLC  
MM-99-100 Disc Wheel Hubs/Brake Drum Automatic Slack Adjuster Maintenance Manual Meritor Tire Inflation Systems (MTIS) by P.S.I. Installation and Maintenance Manual 14P  
MM-96173 QPlus LX500 and MX500 Cam Brakes  
Maintenance Manual No. 4 - Brakes  
Maintenance Manual No. 1 - Lubrication  
Arvin Meritor  
Technical Communications  
2135 West Maple Road  
Troy, Michigan 48084  
[www.arvinmeritor.com](http://www.arvinmeritor.com)  
[www.meritorWABCO.com](http://www.meritorWABCO.com)
- Trailer Suspensions - Maintenance Procedures  
Hutchens Industries, Inc.  
P.O. Box 1427 S.S.S.  
Springfield, Missouri 65805  
[www.hutch-susp.com](http://www.hutch-susp.com)
- Manual for Timken Tapered Roller Bearings  
Timken Bearing Equipped - Your Key to Better Maintenance  
Let'er Roll - Bearing Maintenance Manual  
The Timken Co. 1835  
Dueber Ave. SW  
Canton, Ohio 44706  
[www.timken.com](http://www.timken.com)
- Alcoa - Wheel Service Manual  
Aluminum Company of America  
1501 Alcoa Building Pittsburgh,  
PA 15219  
[www.alcoa.com/alcoawheels](http://www.alcoa.com/alcoawheels)
- Care & Service of Highway Truck Tires - Radial & Bias  
Rubber Manufacturers Association  
1901 Pennsylvania Ave., N.W.  
Washington, D.C. 20006
- Installation and Field Maintenance for Spicer Trailer Axles, Brakes & Components  
Heavy Vehicle Technology Center  
Dana Corporation - Division Office  
6938 Elm Valley Drive Kalamazoo,  
MI 49009  
[www.dana.com/trailers](http://www.dana.com/trailers)
- Form No. 5011 Model TR Service Manual  
Indian Head Industries / MGM Brakes  
8530 Cliff Cameron Dr  
Charlotte, NC 28269  
[www.mgmbrakes.com](http://www.mgmbrakes.com)
- Stemco TQM Total Quality Maintenance  
Stemco Manufacturing Company, Inc.  
P. O. Box 1989  
Longview, Texas 75606  
[www.stemco.com/tqm.pdf](http://www.stemco.com/tqm.pdf)
- Accuride Safety & Service Manual  
Accuride Corporation  
2315 Adams Lane  
Henderson, Kentucky 42420  
[www.akwheels.com](http://www.akwheels.com)
- Hendrickson  
L578 Maintenance Procedures  
L579 Alignment Procedures  
L776 HUS Wheelend Maintenance Procedures  
L839 Reapplying Axle Sealant Procedure  
Hendrickson  
800 South Frontage Rd  
Woodridge, IL 60517-4904  
[www.hendrickson-intl.com](http://www.hendrickson-intl.com)
- 86 AR Slider Series Maintenance Procedures  
Tuthill Industries - Reyco Granning  
1205 Industrial Park Drive  
Mt. Vernon, MO 65712  
[www.reycogranning.com](http://www.reycogranning.com)
- ConMet Wheel End Technology  
ConMet  
13940 Rivergate Blvd  
Portland, OR 97203  
[www.conmet.com](http://www.conmet.com)
- Haldex  
L30030 TrailerABS Installation & Service Manual  
XLSB05401 Anchorlok Spring Brake Maintenance  
L30033 Service Manual Truck and Trailer Applications  
Automatic Brake Adjusters  
10930 N. Pomona Avenue  
Kansas City, MO 64153  
[www.hbsna.com](http://www.hbsna.com)
- Bendix Commercial Vehicle Systems LLC  
901 Cleveland Street  
Elyria, OH 44035  
[www.bendix.com](http://www.bendix.com)
- TSE Engineering Report  
TSE Brake Actuators  
3183 S. Parkway Drive  
Fresno, CA 93725-2317  
[www.tsebrakes.com](http://www.tsebrakes.com)
- Hayes-Lemmerz  
Tech Info Bulletins T198-0001 through -0011  
Hayes-Lemmerz  
428 Seiberling Street Akron,  
OH 44036  
<http://ch.hayes-lemmerz.com>
- CR Scotseal Technical Bulletin N TBF 9401  
Chicago Rawhide  
900 North State Street  
Elgin, IL 60123  
[www.chicago-rawhide.com](http://www.chicago-rawhide.com)
- Gunite Slack Adjuster Service Manual  
Gunite Heavy Duty Brake Drums Maintenance & Installation Guide  
Gunite Disc Wheel Hub Maintenance & Installation Guide  
Gunite  
302 Peoples Avenue  
Rockford, IL 61104-7092  
[www.gunite.com](http://www.gunite.com)
- Walther EMC  
3501 Shotwell Drive  
Franklin, OH 45005
- Truck-Lite  
310 E. Elmwood Ave.  
Falconer, NY 14733  
[www.truck-lite.com](http://www.truck-lite.com)
- Grote  
2600 Lanier Drive  
Madison, IN 47250  
[www.grote.com](http://www.grote.com)
- Technical Info - 7 Way Maintenance  
Top Ten Cure for Corrosion  
Phillips Industries  
11250 Pagemill Road  
Dallas, TX 75243  
[www.phillipsind.com](http://www.phillipsind.com)
- Great Dane Service Bulletin  
No. 3371 with ts attachment  
TMC56 Chassis Study Group Information

Report: 2002-1

For further data on how to obtain information on products not listed in this bibliography, contact Great Dane Trailers, P.O. Box 67, Savannah, Georgia 31402, or the manufacturer of the specified product.

# APPENDIX



## WARRANTY

### GREAT DANE LLC VANS AND PLATFORM TRAILERS

This is to certify that **GREAT DANE LLC ("GREAT DANE")** warrants the first purchaser only (hereinafter referred to as "Purchaser"), subject to the conditions stated herein, that the described new trailers shall be free from defects in materials and workmanship, when properly maintained, and under normal use and service which means the loading, unloading, and transportation of uniformly distributed legal loads of noncorrosive cargo, adequately restrained and secured, in a manner which does not subject the trailers to strains or impact greater than are imposed by normal use. Total weight of trailer and cargo must not exceed the Gross Vehicle Weight Rating (GVWR) set forth on the vehicle identification plate fasted to the trailer at the factory, and the loading of each axle must not exceed the Gross Axle Weight Rating (GAWR) listed on the name plate. Total Weight of lift truck and cargo must not exceed published floor rating.

**THE SOLE AND EXCLUSIVE REMEDY OF PURCHASER UNDER THIS WARRANTY SHALL BE THE REPAIR OR REPLACEMENT, AT THE OPTION OF GREAT DANE LLC, OF ANY PORTION OF SAID TRAILER WHICH WAS MANUFACTURED BY GREAT DANE LLC AND WHICH HAS FAILED AS A RESULT OF A DEFECT IN MATERIALS OR IN WORKMANSHIP.**

This warranty will remain in effect from date of manufacture, as long as it remains in the possession of the first purchaser. Repairs under this warranty shall be at repair facilities designated by **GREAT DANE**. Transportation expenses to the repair facility are to be borne by the Purchaser.

**THE EXPRESS WARRANTY HEREIN IS IN LIEU OF ANY AND ALL OTHER WARRANTIES RELATING TO THE STEEL MAIN BEAM, EXPRESS OR IMPLIED. NO WARRANTY OF MERCHANTABILITY IS MADE, AND THERE ARE NO WARRANTIES AS TO THE STEEL MAIN BEAM WHICH EXTEND BEYOND THE DESCRIPTION OF THE FACE HEREOF. GREAT DANE'S STANDARD WARRANTY SHALL APPLY TO ALL OTHER COMPONENTS OF THE TRAILER.**

This warranty will expire sixty (60) months from date of manufacture, and repairs under this warranty shall be at repair facilities designated by **GREAT DANE**. Transportation expenses to the repair facility are to be borne by the Purchaser.

**THE EXPRESS WARRANTY HEREIN IS IN LIEU OF ANY AND ALL OTHER WARRANTIES, EXPRESS OR IMPLIED. NO WARRANTY OF MERCHANTABILITY IS MADE, AND THERE ARE NO WARRANTIES WHICH EXTEND BEYOND THE DESCRIPTION OF THE FACE HEREOF.**

The express warranty herein does not apply to any trailer which shall have been repaired or altered without prior written approval of **GREAT DANE** in any way so as , in the judgment of GREAT DANE LLC to adversely affect its stability or reliability; neither shall the express warranty provisions apply to any trailer which has been subjected to misuse, abuse or accident.

The express warranty provisions herein does not apply to, and **GREAT DANE** makes no warranties, express or implied, with respect to

- (1) Tires, refrigeration units, batteries and lift gates to which the manufacturer's warranty applies;
- (2) Parts, accessories and other items which are specified by Purchaser;
- (3) Used items furnished by Purchaser for installation on new Great Dane trailers; and
- (4) Items which, while not defective, are subject to fair wear and tear and because of which, replacement may have to be made during the warranty period.

With respect to parts, accessories and other items which are standard on new Great Dane trailers, the express warranty herein is limited in time and scope to those conditions contained in the warranty of the manufacturer of the part or accessory. **GREAT DANE AND PURCHASER AGREE THAT GREAT DANE WILL HAVE NO LIABILITY FOR ANY CARGO LOSS, USAGE LOSS, OR OTHER CONSEQUENTIAL OR INCIDENTAL DAMAGES ALLEGED TO HAVE BEEN CAUSED BY ANY DEFECT IN THE TRAILERS.** The provisions of this warranty shall be interpreted and construed in accordance with the laws of Georgia.

IN WITNESS WHEREOF, **GREAT DANE** has caused this Warranty to be signed by its duly authorized officer:

VIN No. \_\_\_\_\_

Date Manufactured \_\_\_\_\_

ALL USED TRAILERS ARE SOLD IN "AS IS" CONDITION AND THERE ARE NO WARRANTIES, EXPRESS OR IMPLIED, ON USED TRAILERS.

REVISED: JUNE 8, 2023

**GREAT DANE** LLC

PRESIDENT AND CHIEF OPERATING OFFICER

GREAT DANE









[WWW.GREATDANE.COM](http://WWW.GREATDANE.COM)

Great Dane and the oval are registered trademarks  
of Great Dane Limited Partnership

779 AJD 0524